



PSO140-10S, PSO165  
LPSO & LLPSO

*Parts Catalog*

*Bulletin No. T210-PSO140-10S*

June 1996



# CONTENTS

RATIO TABLE.....	1
GEARS AND RELATED PARTS - MAIN SECTION.....	2-5
DRIVE GEAR GROUP.....	2-3
MAINSHAFT GROUP.....	2-3
COUNTERSHAFT GROUP.....	4-5
GEARS AND RELATED PARTS - RANGE SECTION.....	6-9
COUNTERSHAFT AND SYNCHRONIZER GROUP.....	6-7
MAINSHAFT GROUP.....	8-9
END YOKE TABLE.....	9
CLUTCH HOUSING GROUP.....	10-11
DRIVE GEAR BEARING GROUP.....	12-13
MAIN CASE GROUP.....	12-13
OPTILUBE PUMP AND RELATED PARTS.....	14-15
WILLIAMS AIR CONTROL AND INTERLOCK GROUP.....	16-17
SHIFT BAR AND FORK ASSEMBLY.....	18-19
RANGE CASE GROUP.....	20-21
RANGE PISTON HOUSING AND SHIFT FORK GROUP.....	20-21
COUNTERSHAFT BEARING CAP GROUP.....	20-21
REAR BEARING CAP GROUP.....	20-21
SHIFT TOWER ASSEMBLY AND RELATED PARTS.....	22-23
UPPER SHIFT LEVER .....	22-23
AIR HARNESS.....	22-23
FLOOR BOARD BOOT.....	22-23
SHIFT KNOB ASSEMBLY.....	22-23
LOWER SHIFT LEVER AND TOWER.....	22-23
TOWER CONTROL HOUSING.....	22-23
REMOTE CONTROL ASSEMBLY.....	24-25
CLUTCH RELEASE CODE TABLE.....	26-27
OVERHAUL KITS - MAJOR AND MINOR.....	28-29
OIL COOLER KIT AND PLUMBING DIAGRAM.....	30
AIR CONTROL PLUMBING DIAGRAM.....	31
TABULATED BILLS OF MATERIAL.....	32-41
SUPERSESSION LIST.....	42-43



# PRO-SHIFT 10 SPEED MODELS (1400-1650 lb-ft) RATIO TABLE and IDENTIFICATION

**T210-PSO140-10S**

## RATIO TABLE

Models	PS145-10D LPS145-10D LLPS145-10D	Base B/M 301607 Base B/M 301611 Base B/M 301703	PSO140-10S LPSO140-10S LLPSO140-10S PSO150-10S LPSO150-10S LLPSO150-10S PSO165-10S	Base B/M 301562 Base B/M 301573 Base B/M 301705 Base B/M 301563 Base B/M 301574 Base B/M 301706 Base B/M 301564
<b>Speeds</b>				
1st	14.95		12.54	
2nd	11.01		9.24	
3rd	7.98		6.68	
4th	5.98		4.80	
5th	4.50		3.60	
6th	3.32		2.61	
7th	2.45		1.92	
8th	1.77		1.39	
9th	1.33		1.00	
10th	1.00		0.75	
Rev	16.71		14.02	

Models	PS85-10V	Base B/M 301587	PSO115-10V PSO125-10V PSO145-10V	Base B/M 301588 Base B/M 301589 Base B/M 301582
<b>Speeds</b>				
1st	19.02		13.59	
2nd	14.02		10.01	
3rd	10.13		7.24	
4th	7.28		5.20	
5th	5.20		3.71	
6th	3.66		2.61	
7th	2.70		1.92	
8th	1.95		1.39	
9th	1.40		1.00	
10th	1.00		0.72	
Rev	15.19		15.19	

The Name Plate NP-96 affixed to the rear left hand side of the Transmission is stamped with Information.

**Identification:**  
In requesting more information on the Transmissions, please furnish this Information.

Serial No.

B/M No.  Model

**Abbreviations used in this Parts List Include:**  
 N.S. - Not Shown  
 N.S.S. - Not Sold Separately  
 A/R - As Required

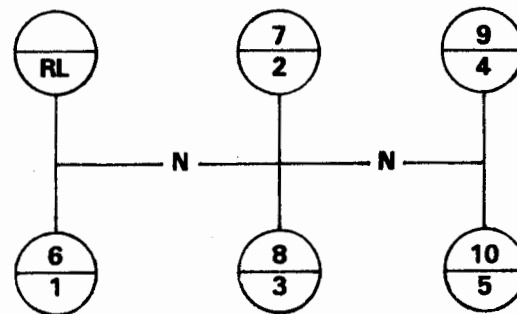

**SHIFT PATTERN**  
(Same for Direct and Overdrive)

PRO-SHIFT 10 SPEED MODELS (1400-1650 lb-ft)  
GEARS and RELATED PARTS - MAIN SECTION



10-PSO140-10S

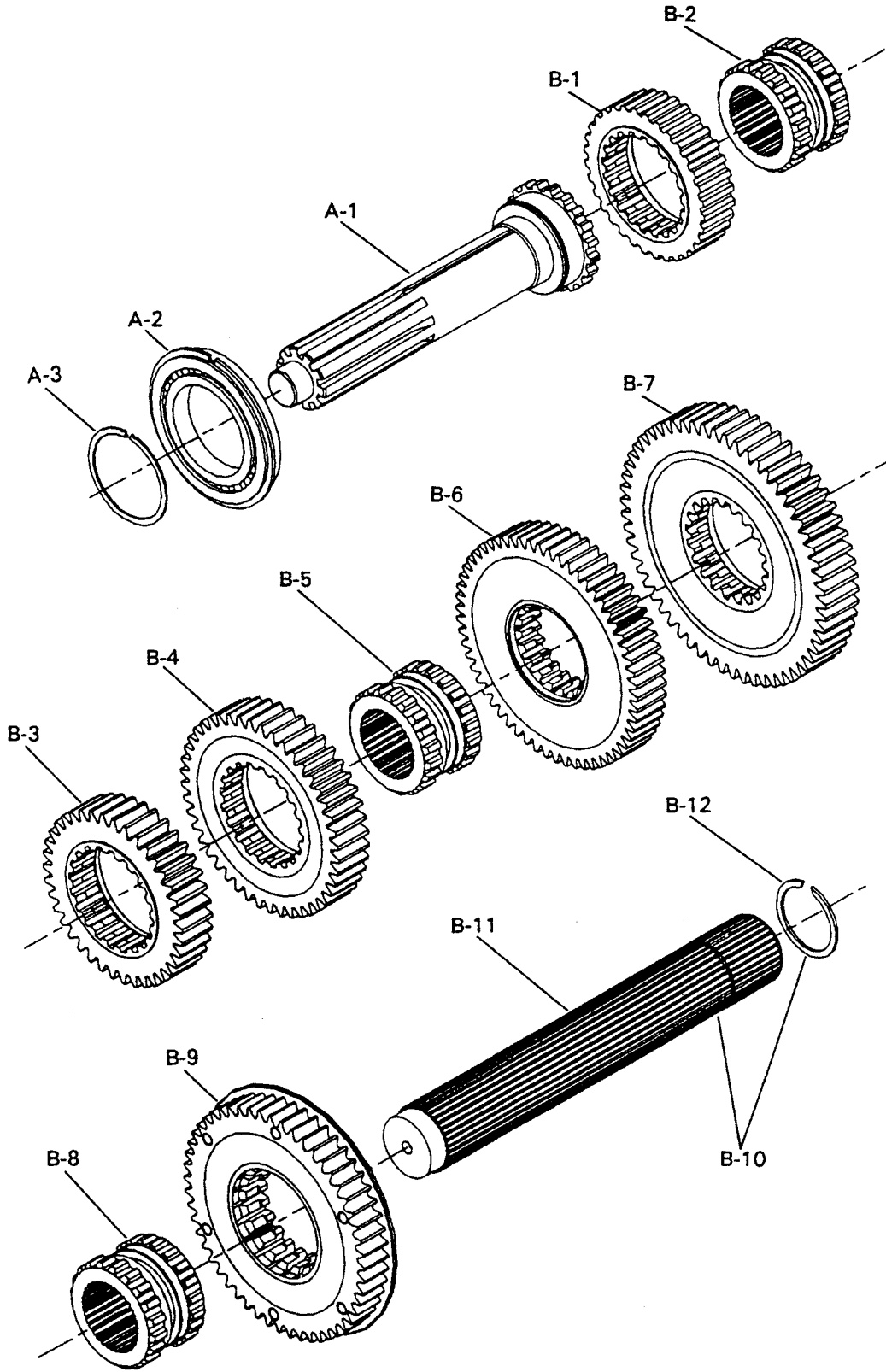



**PRO-SHIFT 10 SPEED MODELS (1400-1650 lb-ft)  
GEARS and RELATED PARTS - MAIN SECTION**

**T210-PSO140-10S**

Ref. No.	Part No.	Description	Qty.
<b>Drive Gear Group - Input Main Section</b>			
A-1	201-35-2	Shaft - Input (2.00"-10 spline #306 (1.180" dia.) Pilot	1
or	201-35-6	Shaft - Input (1.750"-10 spline #205 (.983" dia.) Pilot (PS85-10V and PSO115-10V only)	1
or	201-35-7	Shaft - Input (1.750"-10 spline #306 (1.180" dia.) Pilot (PS85-10V and PSO115-10V only)	1
A-2	313645X	S/Assy. - Bearing & Belleville Snap Ring	1
A-3	201-381-1	Snap Ring - Input Shaft	1
<b>Mainshaft Group Main Section</b>			
B-1	201-8-49	Gear - Drive (5th & 10th) (50T) (All Overdrive Transmissions)	1
or	201-8-57	Gear - Drive (5th & 10th) (44T) (Direct Transmissions)	1
or	201-8-53	Gear - Drive (5th & 10th) (46T) (Direct Vocational Transmissions)	1
B-2	201-465-5	Collar - M/S Clutch (4th, 5th & 9th, 10th)	1
B-3	201-8-48	Gear - Mainshaft (4th & 9th) (40T) (Overdrive Transmissions)	1
or	201-8-58	Gear - Mainshaft (4th & 9th) (54T) (Direct Transmissions)	1
or	201-8-49	Gear - Mainshaft (4th & 9th) (50T) (Direct Vocational Transmissions)	1
or	201-8-53	Gear - Mainshaft (4th & 9th) (46T) (Overdrive Vocational Transmissions)	1
B-4	201-8-46	Gear - Mainshaft (3rd & 8th) (46T)	1
B-5	201-465-2	Collar - M/S Clutch (2nd, 3rd & 7th, 8th)	1
B-6	201-8-45	Gear - Mainshaft (2nd & 7th) (62T)	1
B-7	201-8-44	Gear - Mainshaft (1st) (62T)	1
B-8	201-465-2	Collar - M/S Clutch (1st & Rev.)	1
B-9	201-8-10-1X	Gear - M/Shaft Reverse (Includes Thrust Ring & Rivets)	1
B-10	201-362-1-1X	Kit - Mainshaft & Snap Ring	1
B-11	N.S.S.	Mainshaft	1
B-12	201-381-3	Snap Ring - Mainshaft Drive Gear - Range	1

N.S.S. - Not Sold Separately

PRO-SHIFT 10 SPEED MODELS (1400-1650 lb-ft)  
GEARS and RELATED PARTS - MAIN SECTION



T210-PSO140-10S

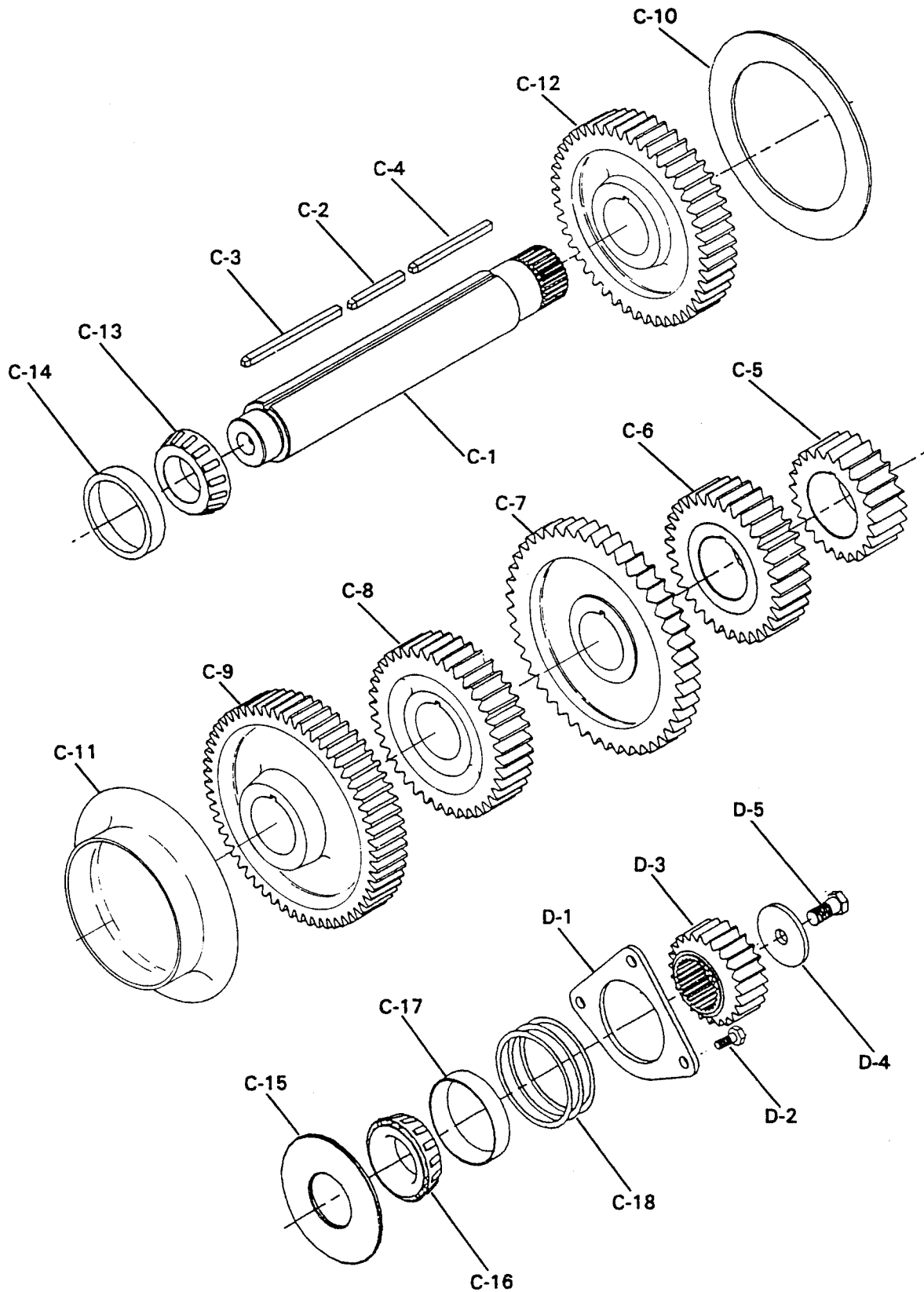



**PRO-SHIFT 10 SPEED MODELS (1400-1650 lb-ft)  
GEARS and RELATED PARTS - MAIN SECTION**

**T210-PSO140-10S**

Ref. No.	Part No.	Description	Qty.
<b>Countershaft Group Main Section</b>			
C-1	201-30-14	Countershaft - Main	2
C-2	201-210-4-2	Key - Countershaft Gear - Middle	2
C-3	201-210-4-3	Key - Countershaft Gear - Front	2
C-4	201-210-4-1	Key - Countershaft Gear - Rear	2
C-5	201-196-36	Gear - Countershaft (1st & 6th) (28T)	2
C-6	201-196-38	Gear - Countershaft (2nd & 7th) (38T)	2
C-7	201-312-3	Gear - Countershaft PTO Drive	2
C-8	201-196-42	Gear - Countershaft (3rd & 8th) (39T)	2
C-9	201-196-40	Gear - Countershaft (4th & 9th) (63T) (Overdrive Transmissions)	2
or	201-196-50	Gear - Countershaft (4th & 9th) (61T) (Direct Transmissions)	2
or	201-196-41	Gear - Countershaft (4th & 9th) (59T) (Direct Vocational Transmissions)	2
or	201-196-45	Gear - Countershaft (4th & 9th) (76T) (Overdrive Vocational Transmissions)	2
C-10	201-47-2	Ring - Countershaft Thrust (Flat)	2
C-11	201-47-5	Ring - Countershaft H.E. Gear Thrust	2
C-12	201-196-41	Gear - Countershaft H.E. (5th & 10th) (59T) (All Overdrive Transmissions)	2
or	201-196-49	Gear - Countershaft H.E. (5th & 10th) (66T) (Direct Transmissions)	2
or	201-196-45	Gear - Countershaft H.E. (5th & 10th) (76T) (Direct Vocational Transmissions)	2
C-13	551013	Bearing - Cone Front Countershaft	2
C-14	550375	Bearing - Cup Front Countershaft	2
C-15	201-47-3	Ring - Countershaft (1st) Thrust	2
C-16	550182	Bearing - Cone Rear Countershaft	2
C-17	550375	Bearing - Cup Rear Countershaft	2
C-18	201-228-1-1	Shim - Countershaft Rear Bearing (.005 thick)	A/R
or	201-228-1-2	Shim - Countershaft Rear Bearing (.010 thick)	A/R
or	201-228-1-3	Shim - Countershaft Rear Bearing (.015 thick)	A/R
or	201-228-1-4	Shim - Countershaft Rear Bearing (.020 thick)	A/R
or	201-228-1-5	Shim - Countershaft Rear Bearing (.030 thick)	A/R
C-19	201-228-1-6	Shim - Countershaft Rear Bearing (.090 thick)	
D-1	201-360-1	Plate - Retainer Countershaft	1
D-2	545002-1	Screw - Plate Retaining Countershaft	3
		If Less Optilube (B/M 301503, 301506, 301517, 301523, 301545, 301546)	6
D-3	201-196-12	Gear - Countershaft Reverse - Range (21T)	2
D-4	330952	Washer - Countershaft Reverse Drive Gear Retaining	2
D-5	545001-5	Screw - Reverse Drive Gear Retaining Washer	2

A/R - As Required

**PRO-SHIFT 10 SPEED MODELS (1400-1650 lb-ft)**  
**GEARS and RELATED PARTS - RANGE SECTION**



T210-PSO140-10S

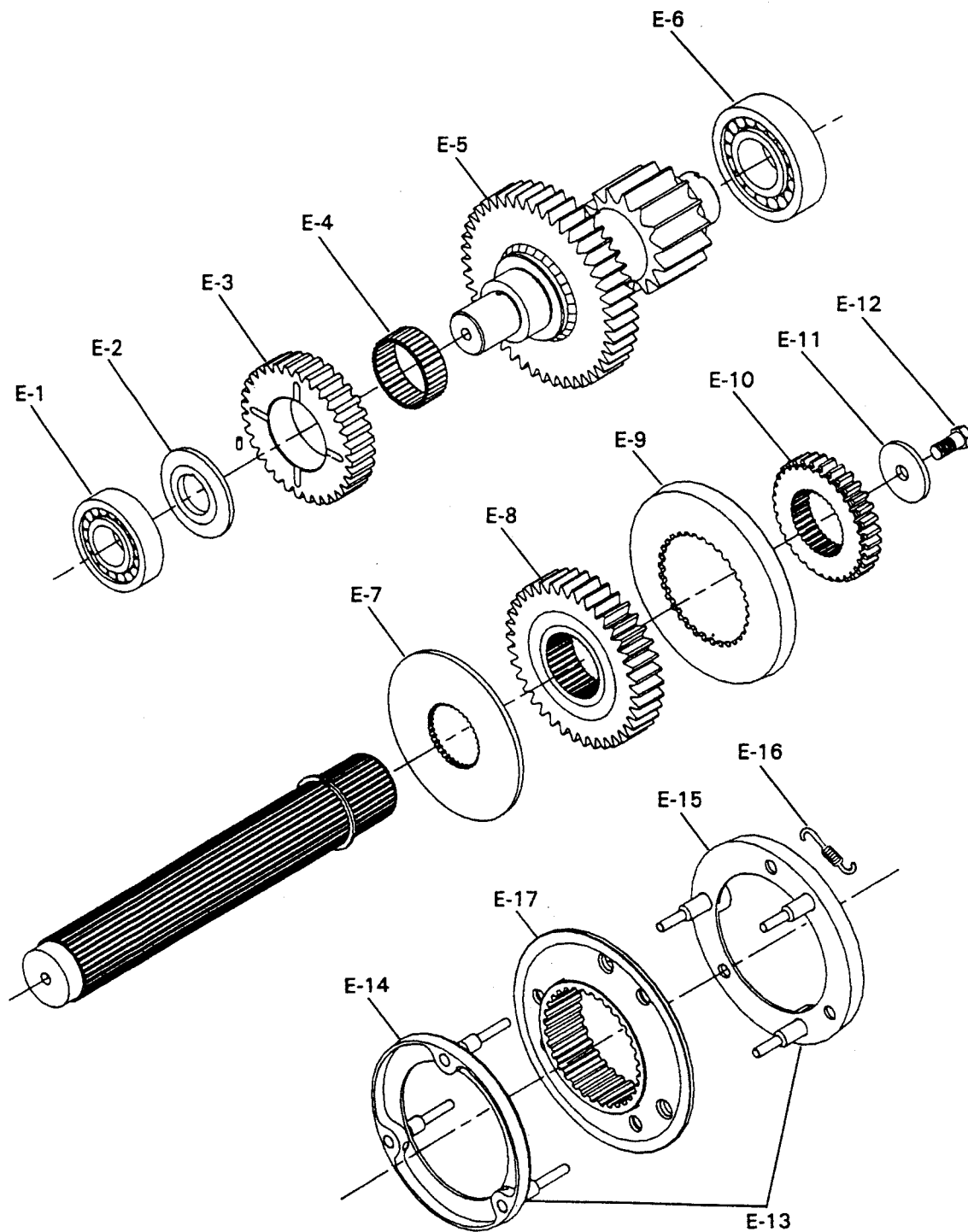



**PRO-SHIFT 10 SPEED MODELS (1400-1650 lb-ft)  
GEARS and RELATED PARTS - RANGE SECTION**

**T210-PSO140-10S**

<b>Ref. No.</b>	<b>Part No.</b>	<b>Description</b>	<b>Qty.</b>
<b>Countershaft and Synchronizer Group Range Section</b>			
E-1	550996	Bearing - Countershaft Front	2
E-2	330955	Washer - Countershaft Reverse Idler Thrust	2
E-3	201-5-2	Gear - Reverse Idler Countershaft	2
E-4	550997	Bearing - Needle Reverse Idler	2
E-5	201-30-19	Countershaft S/Assy. - Range (20T/48T) (Overdrive Transmissions)	2
or	201-30-12	Countershaft S/Assy. - Range (20T/48T) (Overdrive Transmissions Less Optilube) (B/M 301503, 301506, 301517, 301523, 301545, 301546)	2
or	201-30-17	Countershaft S/Assy. - Range (20T/45T) (Direct Transmissions)	2
or	201-30-16	Countershaft S/Assy. - Range (20T/52T) (All Vocational Transmissions)	2
E-6	550998	Bearing - Countershaft Rear	2
E-7	201-47-6	Ring - Thrust Mainshaft Drive Gear	1
E-8	201-8-51	Gear - Mainshaft Head End (26T) (Overdrive Transmissions)	1
or	201-8-59	Gear - Mainshaft Head End (26T) (Direct Transmissions)	1
or	201-8-55	Gear - Mainshaft Head End (26T) (All Vocational Transmissions)	1
E-9	201-494-1	Race - Synchronizer Outer	1
E-10	201-466-2	Gear - Clutch Drive (High Range)	1
E-11	330954	Washer - Mainshaft Clutch Gear Retaining (High Range)	1
E-12	545001-5	Screw - Clutch Gear Retaining Washer (High Range)	1
E-13	201-563-1-1X	Synchronizer - High & Low (Includes E-14, E-15, & E-16)	1
E-14	N.S.S.	S/Assy. - Synchronizer - High Range	1
E-15	N.S.S.	S/Assy. - Synchronizer - Low Range	1
E-16	201-72-9	Spring - Extension	3
E-17	201-465-4	Collar - Clutch - High & Low Range	1

N.S.S. - Not Sold Separately

**PRO-SHIFT 10 SPEED MODELS (1400-1650 lb-ft)**  
**GEARS and RELATED PARTS - RANGE SECTION**



**T210-PSO140-10S**

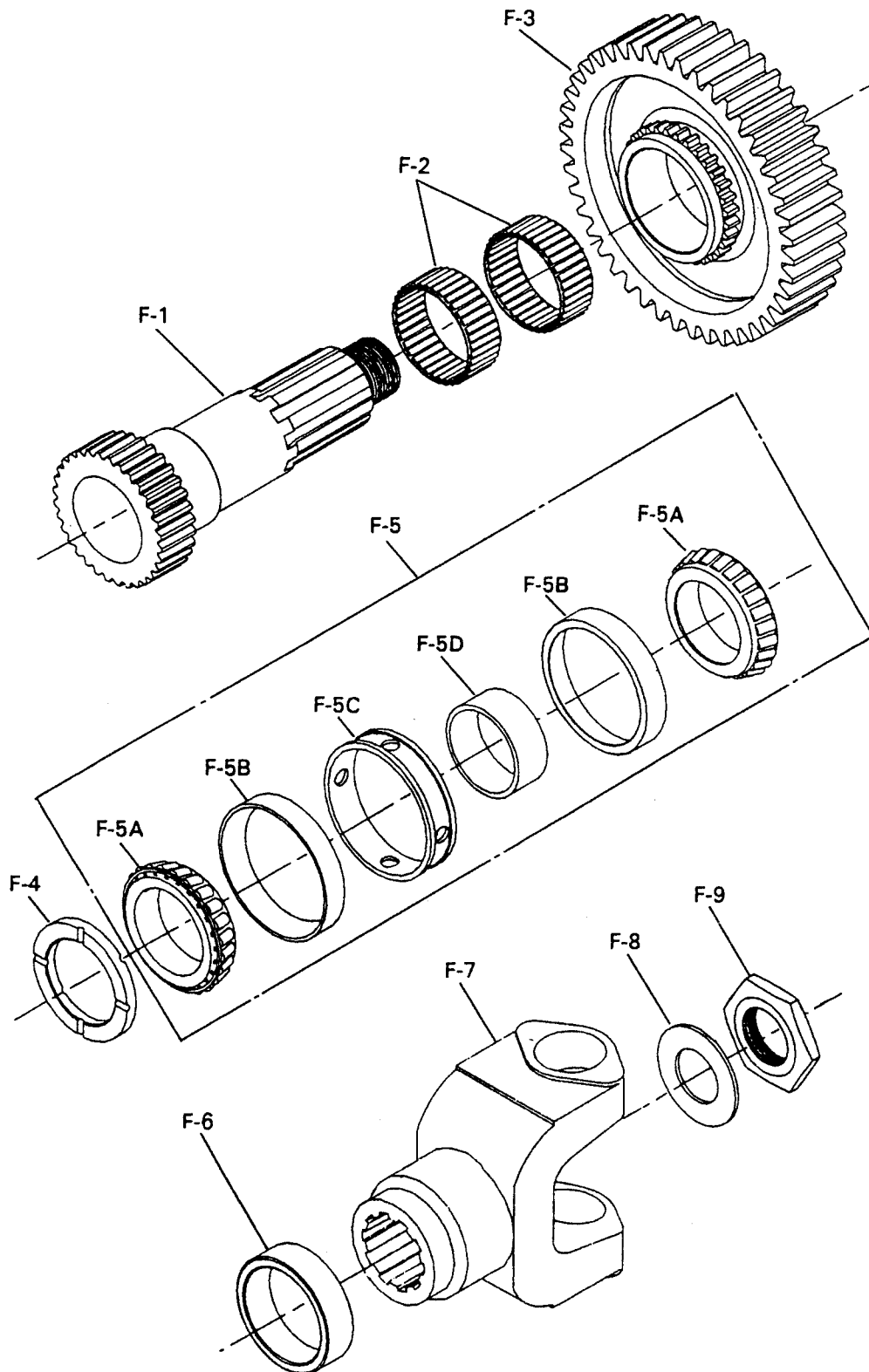



**PRO-SHIFT 10 SPEED MODELS (1400-1650 lb-ft)  
GEARS and RELATED PARTS - RANGE SECTION**

**T210-PSO140-10S**

Ref. No.	Part No.	Description	Qty.
<b>Mainshaft Group - Output Range Section</b>			
F-1	201-362-3	Output Shaft	1
F-2	313668X	Kit - Needle Bearing - Output Shaft (Includes (2) pcs. 550975)	1
F-3	201-8-41	Gear - Output - Low Range (52T)	1
F-4	201-47-4	Washer - Thrust Output Shaft	1
F-5	313628X	S/Assy. - Bearing and Spacer Output Shaft	1
F-5A	N.S.S.	Bearing - Cone Output Shaft	2
F-5B	N.S.S.	Bearing - Cup Output Shaft	2
F-5C	N.S.S.	Spacer - Bearing Cup Output Shaft	1
F-5D	N.S.S.	Spacer - Bearing Cone Output Shaft	1
F-6	201-37-6	Spacer - Speedometer	1
or	201-452-1	Electronic Speedometer Signal Gear (16 grooves)	1
or	201-452-2	Speedometer Drive Gear (4T) Ratio 3:1	1
	97-453-1	Speedometer Driven Gear (12T)	1
or	201-452-3	Speedometer Drive Gear (8T) Ratio 2:1	1
	97-453-7	Speedometer Driven Gear (16T)	1
F-7	See Table Below	Flange or End Yoke	1
F-8	330734	Washer - Output Shaft Nut	1
F-9	545065	Nut - Output Shaft (1.75"-16 UNEF-3B)	1

**END YOKE TABLE**

Series	Yoke Style	End Yoke Part No.	S End of Hub to C/L Length	Maximum Momentary Joint Angle	Spline Type
1710	Full Round	6-4-6611	5.620"	30 degrees	Stra. sided
1710	Half Round	6-4-6611-1	5.620"	30 degrees	Stra. sided
1760	Full Round	6.3-4-651	6.030"	30 degrees	Stra. sided
1760	Half Round	6.3-4-651-1	6.030"	30 degrees	Stra. sided
1810	Full Round	6.5-4-3451	5.880"	30 degrees	Stra. sided
1810	Half Round	6.5-4-3451-1	5.880"	30 degrees	Stra. sided

N.S.S. - Not Sold Separately

**PRO-SHIFT 10 SPEED MODELS (1400-1650 lb-ft)**  
**CLUTCH HOUSING, FRONT BEARING CAP, and MAIN CASE**



**T210-PSO140-10S**

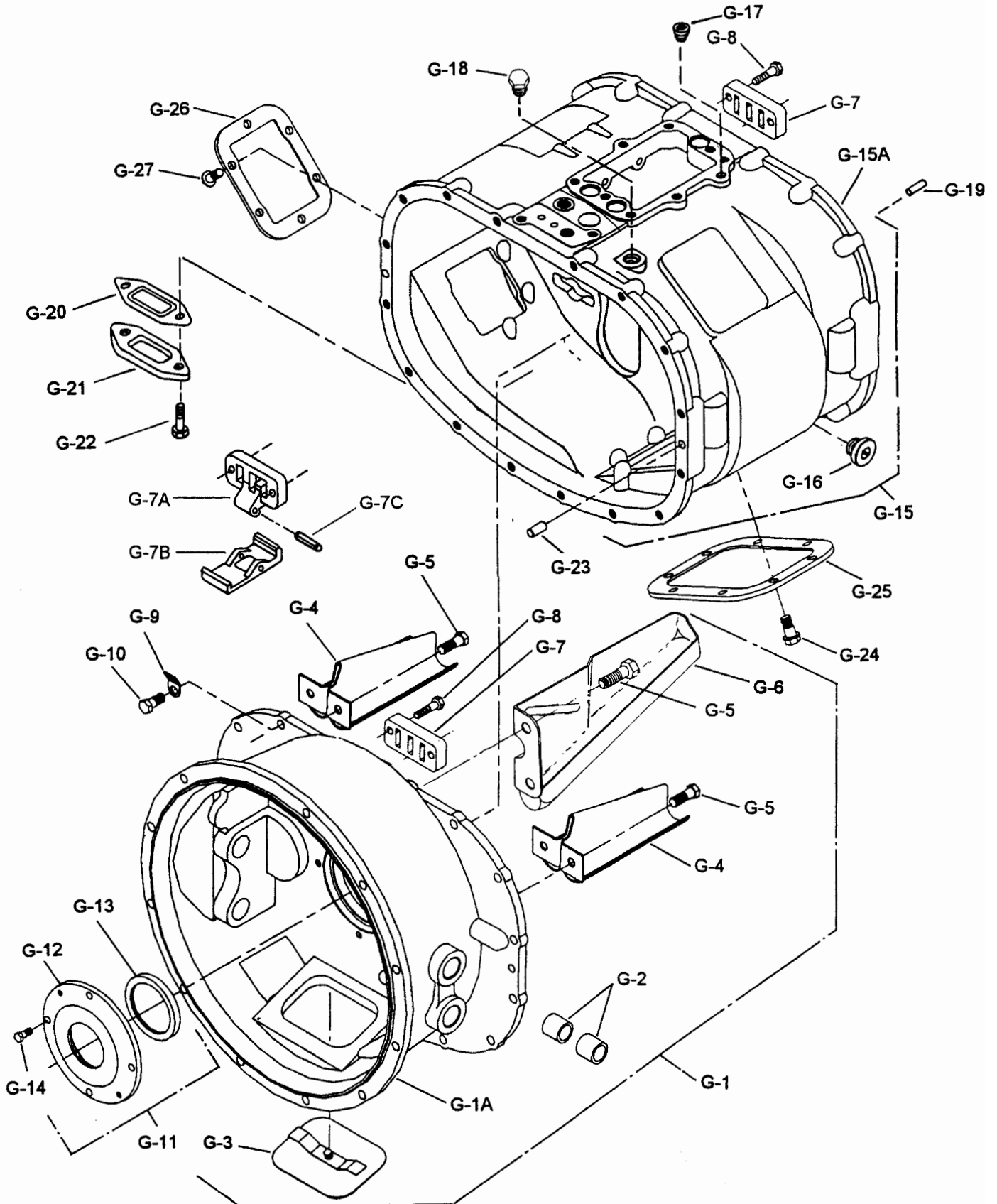



**PRO-SHIFT 10 SPEED MODELS (1400-1650 lb-ft)  
CLUTCH HOUSING, FRONT BEARING CAP, and MAIN CASE**

**T210-PSO140-10S**

Ref. No.	Part No.	Description	Qty.
<b>Clutch Housing Group</b>			
G-1	201-518-10-5X	Clutch Housing, Hand Hole Cover, Oil Troughs, and Bushings (SAE #1) (Iron) (Includes G-1A thru G-6)	1
or	201-518-21-2X	Clutch Housing, Hand Hole Cover, Oil Troughs, and Bushings (SAE #1) (Iron) (Neutral Start Switch Provision) (Includes G-1A thru G-6)	1
or	201-518-14-5X	Clutch Housing, Hand Hole Cover, Oil Troughs, and Bushings (SAE #2) (Iron) (PS86-10V, PSO115-10V Only) (Includes G-1A thru G-6)	1
or	201-518-12-5X	Clutch Housing, Hand Hole Cover, Oil Troughs, and Bushings (SAE #1) (Iron)(Nodal Mount) (Includes G-1A thru G-6)	1
or	201-518-22-2X	Clutch Housing, Hand Hole Cover, Oil Troughs, and Bushings (SAE #1) (Iron)(Nodal Mount) (Neutral Start Switch Provision) (Includes G-1A thru G-6)	1
or	201-518-8-4X	Clutch Housing, Hand Hole Cover, Oil Troughs, and Bushings (SAE #1) (Aluminum for Spicer Lite and Spicer Lite-2 Series) (Includes G-1A thru G-6)	1
or	201-518-20-2X	Clutch Housing, Hand Hole Cover, Oil Troughs, and Bushings (SAE #1) (Aluminum for Spicer Lite and Spicer Lite-2 Series) (Neutral Start Switch Provision) (Includes G-1A thru G-6)	1
or	201-518-19-2X	Clutch Housing, Hand Hole Cover, Oil Troughs, and Bushings (SAE #1) (Aluminum for Spicer Lite and Spicer Lite-2 Series) (Nodal Mount) (Includes G-1A thru G-6)	1
or	201-581-23-2X	Clutch Housing, Hand Hole Cover, Oil Troughs, and Bushings (SAE #1) (Aluminum for Spicer Lite and Spicer Lite-2 Series) (Nodal Mount) (Neutral Start Switch Provision) (Includes G-1A thru G-6)	1
N.S.	201-463-26	"O" Ring - Countershaft Front (Aluminum Clutch Housings Only)	2
G-1A	N.S.S.	Clutch Housing	1
G-2	97-24-8	Bushing - Clutch Release Shaft	4
G-3	97-96-18-1X	S/Assy. - Hand Hole Cover	1
G-4	201-468-1	Oil Trough - Countershaft	2
G-5	545002-13	Screw - Oil Troughs (2 each) (.375"-16 x .500") If less Optilube (B/M 301504, 301505, 301544)	4 6
G-6	201-468-2	Oil Trough - Drive Gear (Less Optilube Only)(B/M 301503, 301506, 301517, 301523, 301545, 301546)	1
N.S.	330934	Magnet - Ceramic (location is Case side bottom)	1
G-7	40-477-1	Support - Shift Rails (Front & Rear)	2
or	40-477-1	Support - Shift Rails (Rear)	1
G-7A	201-477-3	Support - Shift Rails (Front) (Neutral Start Switch Provision)	1
G-7B	201-200-6	Plate - Lift (Neutral Start Switch Provision)	1
G-7C	201-438-15-3	Pin - Roll (2.125") (Neutral Start Switch Provision)	1
G-8	545002-7	Screw - Support Bar (.375"-16 x 1.50") (2 each)	4
G-9	330969	Lift Hook	2
G-10	545001-1	Screw - Clutch Housing (.500"-13 x 1.375")	16

**Front Bearing Cap Group**

See Page 13 for Front Bearing Cap Group and Related Parts (G-11 thru G-14)

**Main Case Group**

See Page 13 for Main Case Group and Related Parts (G-15 thru G-27)

N.S. - Not Shown      N.S.S. - Not Sold Separately

**PRO-SHIFT 10 SPEED MODELS (1400-1650 lb-ft)  
CLUTCH HOUSING, FRONT BEARING CAP, and MAIN CASE**



**T210-PSO140-10S**

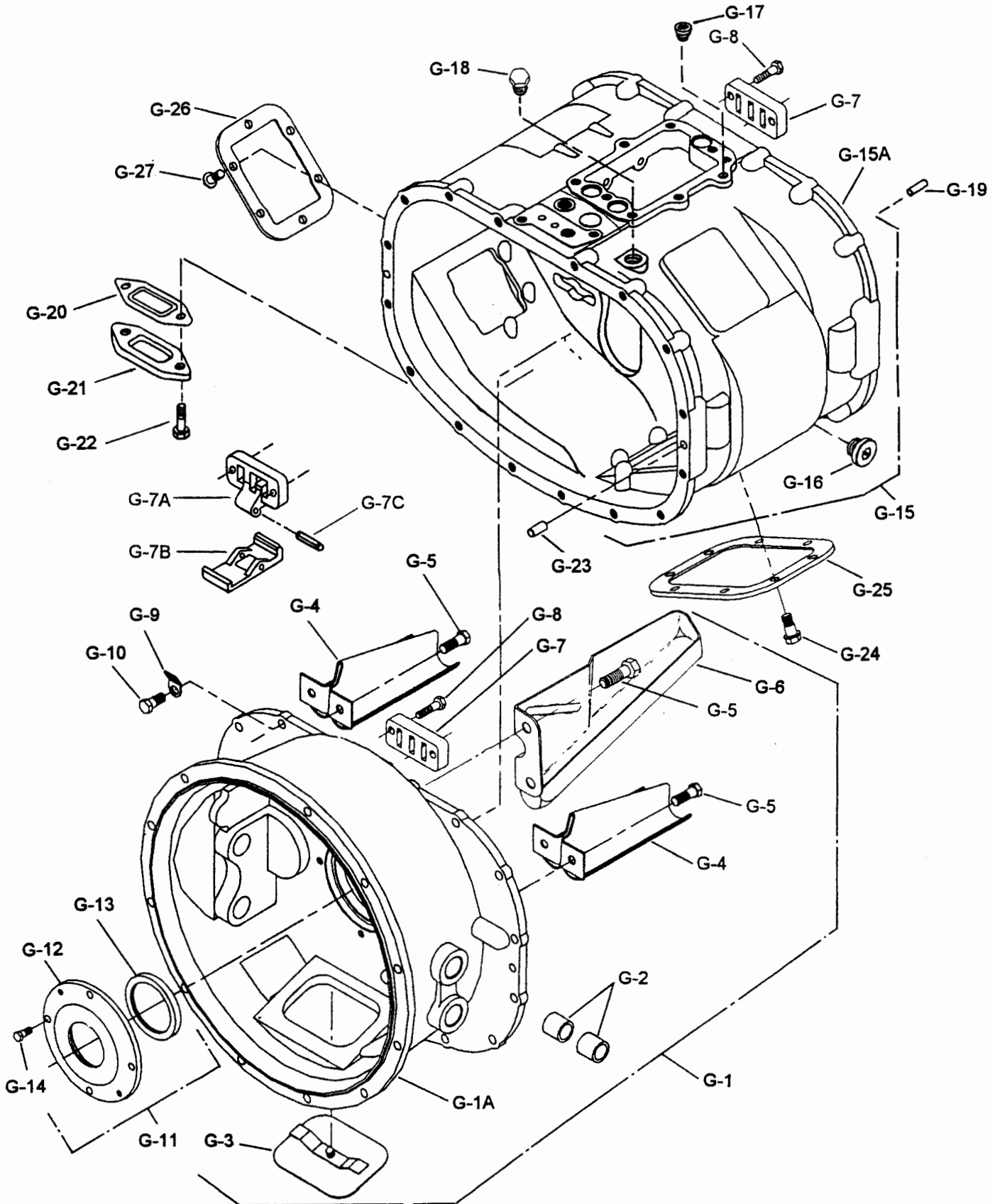



**PRO-SHIFT 10 SPEED MODELS (1400-1650 lb-ft)  
CLUTCH HOUSING, FRONT BEARING CAP, and MAIN CASE**

**T210-PSO140-10S**

Ref. No.	Part No.	Description	Qty.
----------	----------	-------------	------

**Clutch Housing Group**

See Page 11 for Clutch Housing Group and Related Parts (G-1 thru G-10)

Ref. No.	Part No.	Description	Qty.
<b>Front Bearing Cap Group</b>			
G-11	201-19-2-1X	S/Assy. - Drive Gear Bearing Cap and Oil Seal (Includes G-12 thru G-14)	1
G-12	N.S.S.	Bearing Cap	1
G-13	97-463-36-1X	Oil Seal - Drive Cap Bearing Cap (w/installation sleeve)	1
G-14	545002-1	Screw - Drive Gear Bearing Cap (.375"-16 x .875")	4
<b>Main Case Group</b>			
G-15	201-15-13-1X	S/Assy. - Main Case (Includes G-15A thru G-22)	1
or	201-15-2-1X	S/Assy. - Main Case (Includes G-15A thru G-18) (Less Optilube B/M 301503 301506, 301517, 301523, 301545, 301546)	1
or	201-15-10-1X	S/Assy. - Main Case (Includes G-15A thru G-22) (Aluminum for Spicer Lite-2 Series)	1
G-15A	N.S.S.	Case	1
G-16	545123	Plug - Filler & Drain	1
G-17	201-39-4	Plug - Pressure Port Hole	1
G-18	201-39-1	Plug - Case Oil Return Hole	1
N.S.	330934	Magnet - Ceramic (location is at large PTO opening)	1
N.S.	330934	Magnet - Ceramic (location is at large PTO opening)	1
G-19	500597-14	Pin - Alignment (Optilube Mounting Plate)	2
G-20	201-118-4	Gasket - Oil Outlet Cover (location is Case bottom)	1
G-21	201-96-5	Cover - Oil Outlet (location is Case bottom)	1
G-22	545002-2	Screw - Oil Outlet Cover (location is Case bottom)	2
G-23	201-438-3	Pin - Dowel Case	4
G-24	545012	Screw - PTO Aperture Cover (8 Hole)	8
G-25	73-267-1	Cover - PTO (8 Hole)	1
G-26	50-267-2	Cover - PTO (6 Hole)	1
G-27	330800	Screw - PTO Aperture Cover (6 Hole)	6

N.S. - Not Shown      N.S.S. - Not Sold Separately

PRO-SHIFT 10 SPEED MODELS (1400-1650 lb-ft)  
OPTILUBE PUMP and RELATED PARTS



T210-PSO140-10S

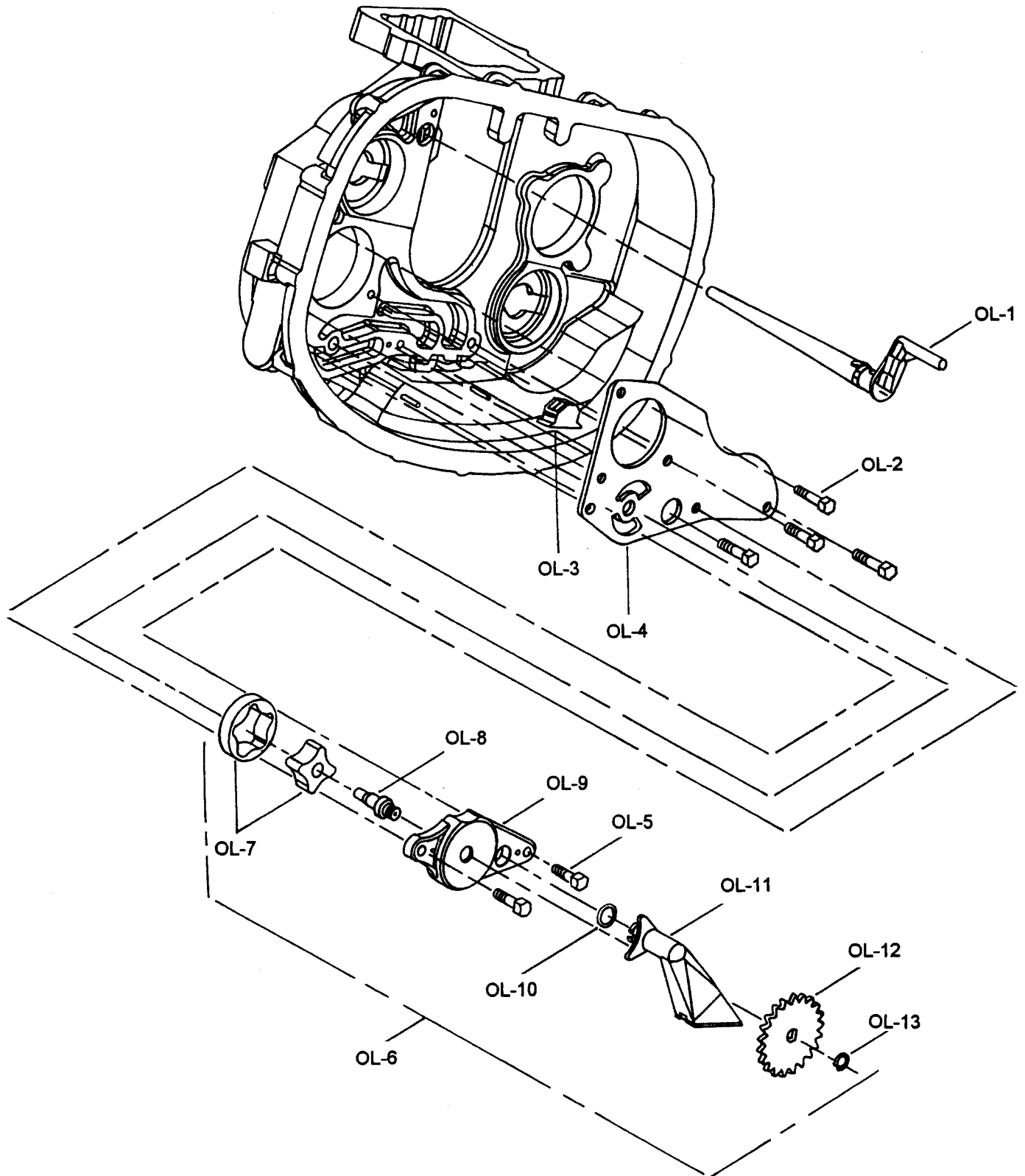



**PRO-SHIFT 10 SPEED MODELS (1400-1650 lb-ft)  
OPTILUBE PUMP and RELATED PARTS**

**T210-PSO140-10S**

<b>Ref. No.</b>	<b>Part No.</b>	<b>Description</b>	<b>Qty.</b>
	<b>201-501-11-2X</b>	<b>Kit - Optilube Pump (Includes OL-1 thru OL-13</b>	<b>1</b>
OL-1	<b>201-420-13X</b>	S/Assy. - Discharge Tube	1
OL-2	<b>545002-1</b>	Screw - Mounting Plate	4
OL-3	<b>201-501-13X</b>	S/Assy. - Oil Bypass Valve	1
OL-4	<b>201-360-2</b>	Plate - Internal Pump Mounting	1
OL-5	<b>545002-2</b>	Screw - Pump Housing	2
OL-6	<b>201-501-11-1X</b>	S/Assy. - Optilube Pump Housing and Gears (Includes OL-7 thru OL-13)	1
OL-7	<b>N.S.S.</b>	Gerotor Element - Internal Oil Pump	1
OL-8	<b>N.S.S.</b>	Shaft - Internal Oil Pump	1
OL-9	<b>N.S.S.</b>	Housing - Pump	1
OL-10	<b>N.S.S.</b>	"O" Ring - Tube	1
OL-11	<b>N.S.S.</b>	S/Assy. - Inlet Tube	1
OL-12	<b>N.S.S.</b>	Gear - Lube Pump Drive	1
OL-13	<b>N.S.S.</b>	Ring - Gear Pump Snap	1

N.S.S. - Not Sold Separately

**PRO-SHIFT 10 SPEED MODELS (1400-1650 lb-ft)  
WILLIAMS CONTROL and INTERLOCK GROUP**



**T210-PSO140-10S**

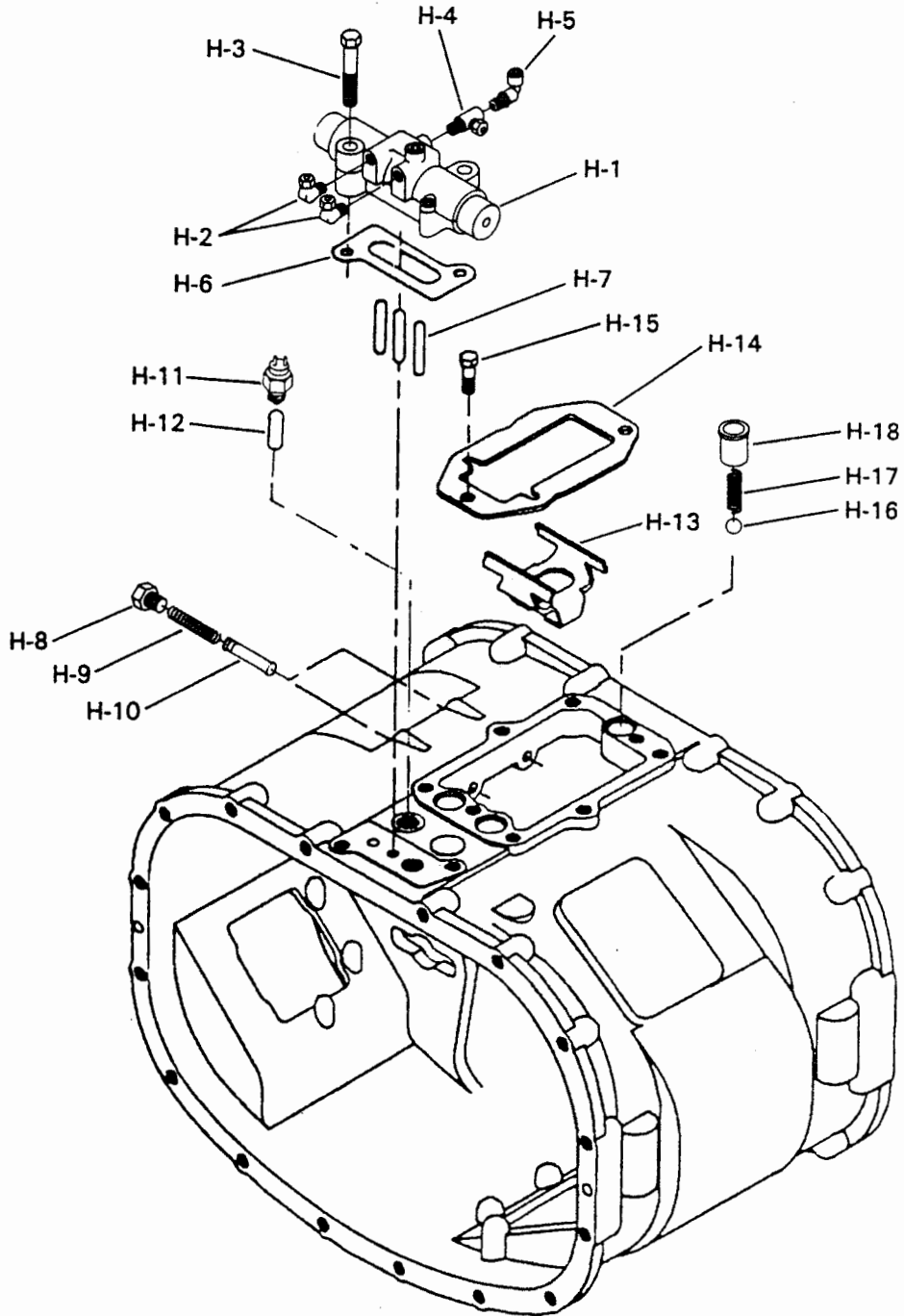



**PRO-SHIFT 10 SPEED MODELS (1400-1650 lb-ft)  
WILLIAMS CONTROL and INTERLOCK GROUP**

**T210-PSO140-10S**

<b>Ref. No.</b>	<b>Part No.</b>	<b>Description</b>	<b>Qty.</b>
		<b>Williams Control</b>	
H-1	313630X	S/Assy. - Williams Control	1
H-2	545025-2	Elbow - Williams Control 90 degree	2
H-3	545028-6	Screw - Williams Control (.438"-14 x 2.250")	2
H-4	545109	Tee - Adapter Williams Control	1
H-5	545130	Elbow - Williams Control	1
N.S.	201-420-7	Tube Support (#38163 Legris Tube Support)	A/R
H-6	201-118-1	Gasket - Williams Control	1
H-7	201-438-5	Pin - Williams Air Control Valve	3
		<b>Interlock Parts Group</b>	
H-8	545128	Plug - 1st and Reverse Spring Plunger	2
H-9	62-72-6	Spring - 1st and Reverse	2
H-10	40-438-1	Pin - Plunger 1st and Reverse	2
H-11	313538	Switch - Back up Light (Pin Connection)	1
or	313552	Switch - Back up Light (Tang Connection)	1
H-12	201-438-2	Pin - Actuating Back up Light Switch	1
H-13	201-200-1	Interlock - Shifter Rail	1
H-14	201-200-2	Plate - Interlock Retainer	1
H-15	330801-1	Screw - Interlock Plate (.438"-14 x .875")	2
H-16	201-80-1	Ball - Poppet	3
H-17	201-72-2	Spring - Poppet Shift Rail	3
H-18	201-487-1	Insert - Poppet Spring & Ball	3

N.S. - Not Shown      A/R - As Required

PRO-SHIFT 10 SPEED MODELS (1400-1650 lb-ft)  
SHIFT BAR and FORK ASSEMBLY



T210-PSO140-10S

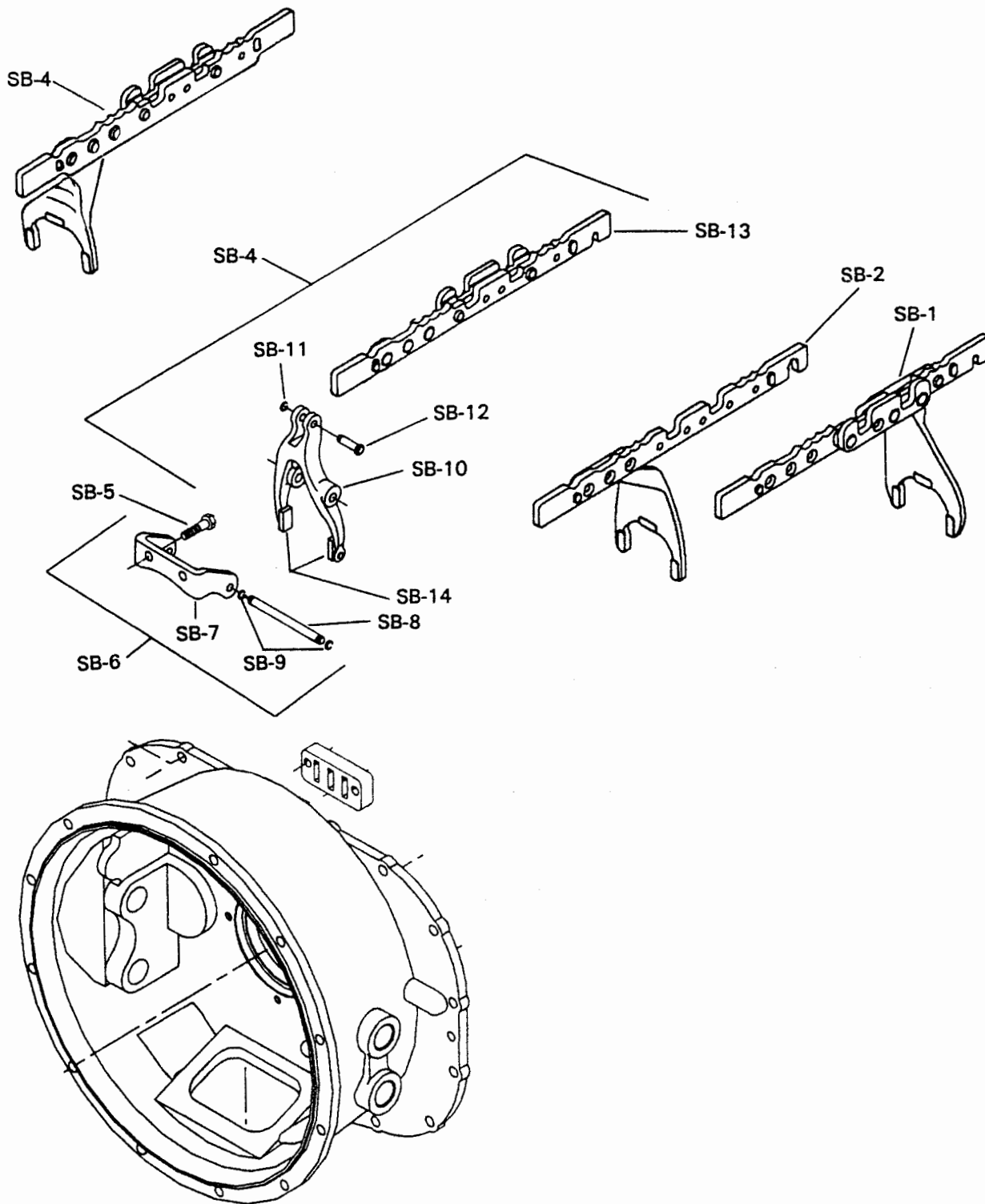



**PRO-SHIFT 10 SPEED MODELS (1400-1650 lb-ft)  
SHIFT BAR and FORK ASSEMBLY**

**T210-PSO140-10S**

Ref. No.	Part No.	Description	Qty.
<b>Shift Bar and Fork Assemblies</b>			
SB-1	<b>313696X</b>	Fork and Bar Assy. - 1st and Reverse	1
or	<b>313795X</b>	Fork and Bar Assy. - 1st and Reverse (Neutral Start Switch Provision)	1
SB-2	<b>313694X</b>	Fork and Bar Assy. - 2nd and 3rd	1
or	<b>313796X</b>	Fork and Bar Assy. - 2nd and 3rd (Neutral Start Switch Provision)	1
SB-4	<b>313642-1X</b>	Bar Assy. - 4th and 5th	1
or	<b>313818-1X</b>	Bar Assy. - 4th and 5th (Neutral Start Switch Provision)	1
and	<b>201-66-18-3X</b>	Fork Assy. - 4th and 5th (Contains SB-8 thru SB-14) (Overdrive Transmissions)	1
or	<b>313695X</b>	Fork and Bar Assy. - 4th and 5th (Direct Transmissions)	1
or	<b>313819X</b>	Fork and Bar Assy. - 4th and 5th (Direct Transmissions) (Neutral Start Switch Provision)	1
SB-5	<b>545029-3</b>	Screw - Fork Mounting Bracket Overdrive (.375" x 1.00")	2
SB-6	<b>201-411-3-1X</b>	<b>Kit - Shift Fork Mounting Bracket, Pin and Snap Rings</b>	1
SB-7	N.S.S.	Mounting Bracket -Overdrive Shift Fork	1
SB-8	N.S.S.	Pin - Mounting	1
SB-9	N.S.S.	Snap Ring - Mounting Bracket Pin	2
<b>REPAIR KITS FOR REF. NO. SB-4</b>			
	<b>313642-1X</b>	<b>Kit - Overdrive Shift Bar, Pins and Snap Rings</b>	1
SB-8	N.S.S.	Pin - Mounting	1
SB-9	N.S.S.	Snap Ring - Mounting Bracket Pin	2
SB-11	N.S.S.	Snap Ring - Clevis Pin	1
SB-12	N.S.S.	Clevis Pin - Shift Fork	1
SB-13	N.S.S.	Shift Bar - 4th and 5th Overdrive	1
	<b>313818-1X</b>	<b>Kit - Overdrive Shift Bar, Pins and Snap Rings with Neutral Start Switch Provision</b>	1
SB-8	N.S.S.	Pin - Mounting	1
SB-9	N.S.S.	Snap Ring - Mounting Bracket Pin	2
SB-11	N.S.S.	Snap Ring - Clevis Pin	1
SB-12	N.S.S.	Clevis Pin - Shift Fork	1
SB-13	N.S.S.	Shift Bar - 4th and 5th Overdrive with Neutral Start Switch Provision	1
	<b>201-66-18-3X</b>	<b>Kit - Overdrive Shift Fork, Pins and Snap Rings</b>	1
SB-8	N.S.S.	Pin - Mounting	1
SB-9	N.S.S.	Snap Ring - Mounting Bracket Pin	2
SB-10	N.S.S.	Shift Fork S/Assy. - 4th and 5th Overdrive	1
SB-11	N.S.S.	Snap Ring - Clevis Pin	1
SB-12	N.S.S.	Clevis Pin - Shift Fork	1
SB-14	<b>201-486-1</b>	Shoe - Overdrive Shift Fork	2
	<b>201-438-6-1X</b>	<b>Kit - Overdrive Shift Fork Mounting Pin and Snap Ring</b>	1
SB-11	N.S.S.	Snap Ring - Clevis Pin	1
SB-12	N.S.S.	Clevis Pin - Shift Fork	1
	<b>201-438-7-1X</b>	<b>Kit - Overdrive Shift Fork Bracket Pin and Snap Rings</b>	1
SB-8	N.S.S.	Pin - Mounting	1
SB-9	N.S.S.	Snap Ring - Mounting Bracket Pin	2

N.S.S. - Not Sold Separately

# PRO-SHIFT 10 SPEED MODELS (1400-1650 lb-ft) RANGE CASE and RELATED PARTS



T210-PSO140-10S

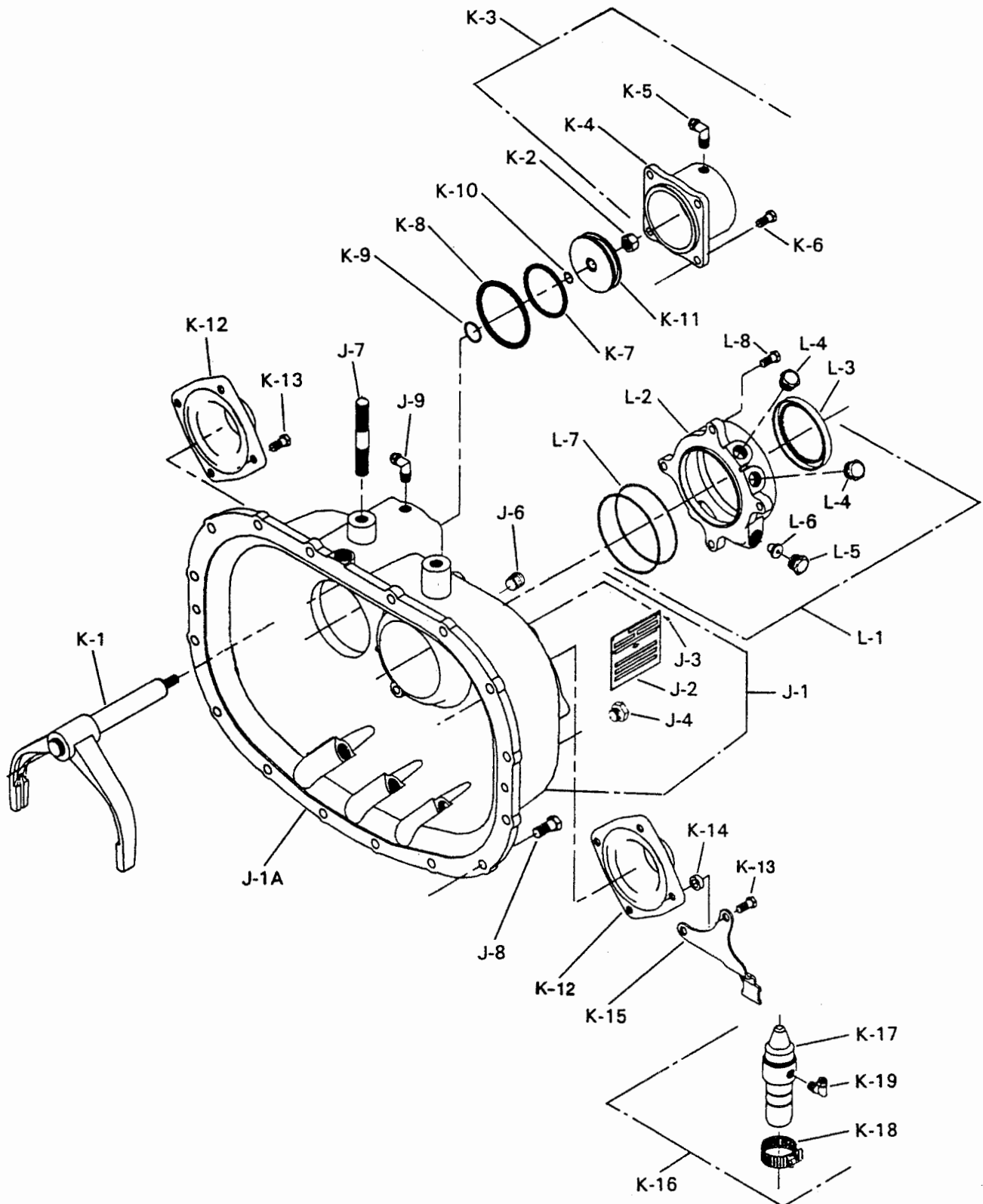



**PRO-SHIFT 10 SPEED MODELS (1400-1650 lb-ft)  
RANGE CASE and RELATED PARTS**

**T210-PSO140-10S**

Ref. No.	Part No.	Description	Qty.
		<b>Range Case Group</b>	
J-1	201-15-3-1X	S/Assy. - Case (Range) (Includes J-1A thru J-6)	1
J-1A	N.S.S.	Case - Range	1
J-2	NP-96	Name Plate	1
J-3	252-SP	Pin - Name Plate	4
N.S.	NP-196	Patent Plate	1
J-4	545123	Plug - Filler & Drain Magnetic	2
J-6	201-39-1	Plug - Temperature Indicator Hole	1
J-7	330360-7	Stud - Rear Mounting (2.375")	2
or	330360-15	Stud - Rear Mounting (3.562")	2
J-8	545001-1	Screw - Range Case (.500"-13 x 1.375")	16
J-9	545025-1	Elbow - 90 degree	1
		<b>Range Piston Housing and Shift Fork Group</b>	
K-1	201-66-23-2X	S/Assy. - Fork and Rod - Range	1
K-2	545045	Nut - Piston Rod - Range	1
K-3	201-501-2-1X	S/Assy - Piston Housing - Range (Includes K-4 thru K-6)	1
K-4	N.S.S.	Housing - Piston - Range	1
K-5	545025-1	Elbow - Piston Housing 90 degree	2
K-6	545002-1	Screw - Piston Housing (.375"-16 x .875")	4
K-7	201-463-1	"O" Ring - Piston Shift - Range	1
K-8	201-463-2	"O" Ring - Piston Housing - Range	1
K-9	201-463-3	"O" Ring - Piston Rod - Range	1
K-10	183-463-6	"O" Ring - Piston to Rod - Range	1
K-11	201-136-7	Piston - Shift - Range	1
		<b>Countershaft Bearing Cap Group</b>	
K-12	201-22-3	Cap - Countershaft Bearing	2
K-13	545002-1	Screw - Bearing Cap (.375"-16 x .875")	6
and	545002-7	Screw - Bearing Cap (.375"-16 x 1.500")	2
and	330969	Lift Hook	1
K-14	500381-4	Spacer - Filter Regulator	4
K-15	201-411-1	Bracket - Filter Regulator	1
K-16	313644X	Kit - Power Control and Mounting Parts (Includes K-17 thru K-19)	1
K-17	313042	S/Assy. - Filter Regulator	1
K-18	330831	Clamp - Filter Regulator Mounting	1
K-19	545025-1	Elbow - Filter Regulator 90 degree	1
		<b>See page 30 for Countershaft Oil Cooler Pump and related parts. (B/M 301503, 301506, 301517, 301523, 301545, 301546 only)</b>	
		<b>Rear Bearing Cap Group</b>	
L-1	201-19-8-1X	S/Assy. - Electronic / Mechanical Bearing Cap Rear (Includes L-2 thru L-5)	1
L-2	N.S.S.	Bearing Cap	1
L-3	201-463-8	Seal - Bearing Cap Rear	1
L-4	545021	Plug - Electronic Speedometer	2
L-5	55-334-1	Plug - Speedometer Outlet	1
L-7	201-228-2-1	Shim - Output Shaft (.005 thick)	A/R
or	201-228-2-2	Shim - Output Shaft (.010 thick)	A/R
or	201-228-2-3	Shim - Output Shaft (.015 thick)	A/R
or	201-228-2-4	Shim - Output Shaft (.020 thick)	A/R
or	201-228-2-5	Shim - Output Shaft (.030 thick)	A/R
L-8	545002-6	Screw - Bearing Cap Rear (.375"-16 x .250")	4

Recommended end play for Rear Mainshaft is .001" - .008"

N.S. - Not Shown    N.S.S. - Not Sold Separately    A/R - As Required

**PRO-SHIFT 10 SPEED MODELS (1400-1650 lb-ft)  
SHIFT TOWER and RELATED PARTS**



**T210-PSO140-10S**

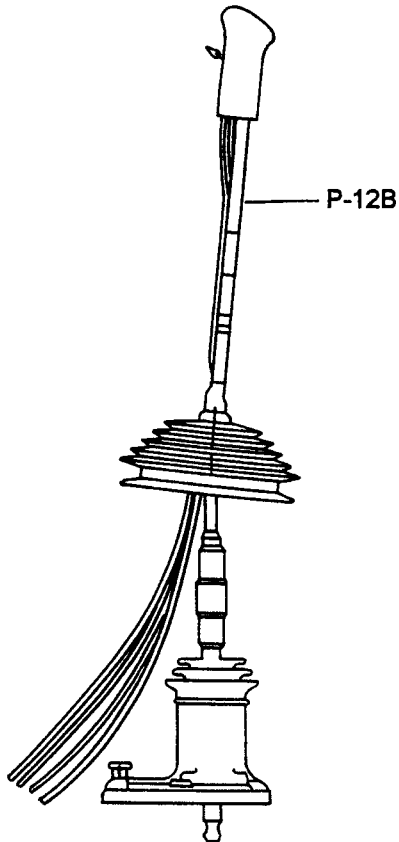

**DOUBLE CRIMP ISOLATOR STYLE**

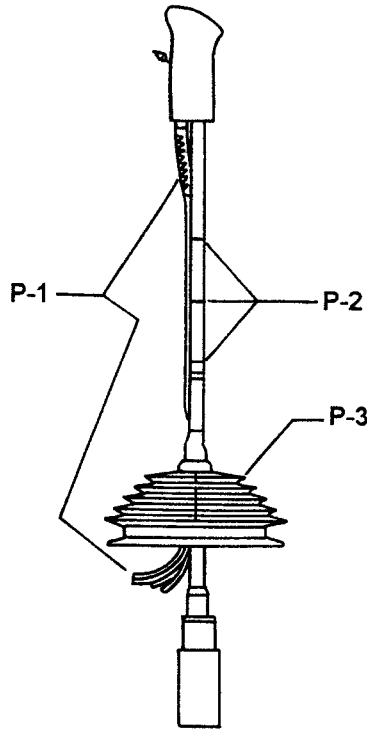

**SINGLE CRIMP  
ISOLATOR STYLE**

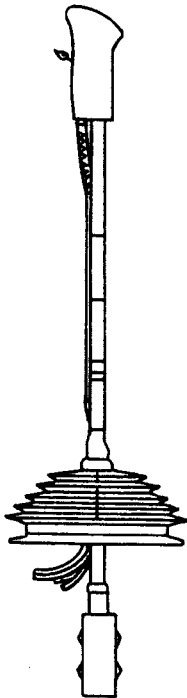

**DOUBLE PIN  
ISOLATOR STYLE**

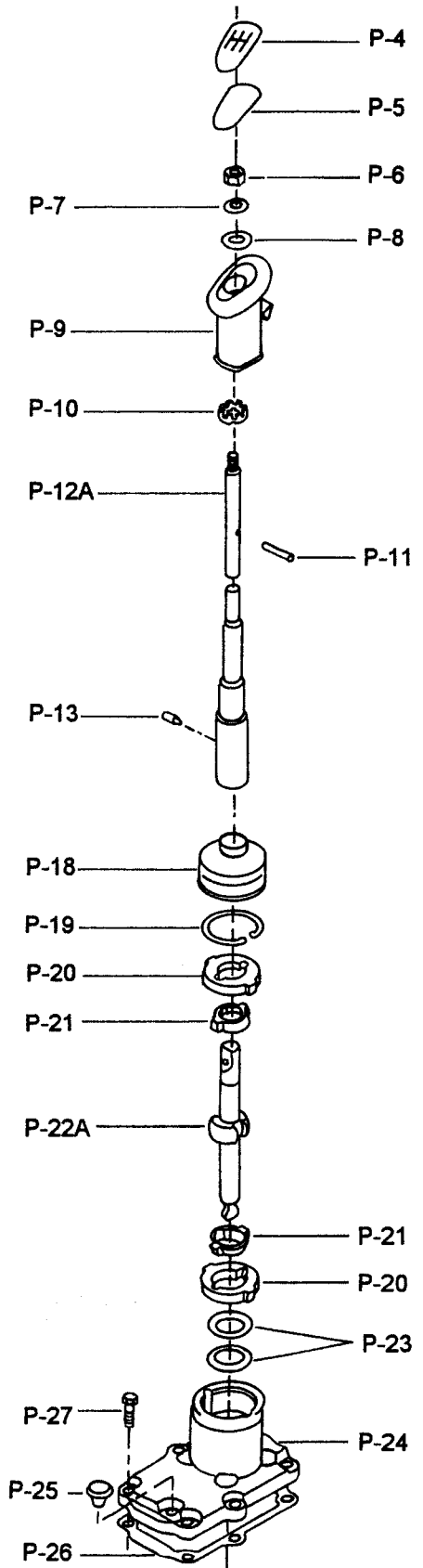
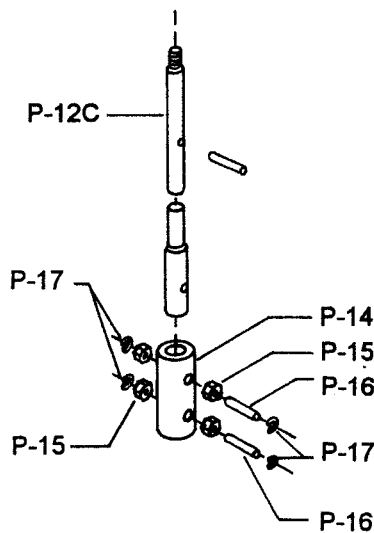



**PRO-SHIFT 10 SPEED MODELS (1400-1650 lb-ft)  
SHIFT TOWER and RELATED PARTS**

**T210-PSO140-10S**

Ref. No.	Part No.	Description	Qty.
N.S.	See Note Below	<b>Shift Lever and Tower Assembly (Includes P-1 thru P-25)</b>	1
N.S.	See Note Below	<b>Upper Lever and Knob Assembly (Includes P-1 thru P-17)</b>	1
P-1	201-420-5-1X	Harness - Air Tubing (48" long)	1
or	201-420-5-2X	Harness - Air Tubing (92" long for Remote Control Use)	1
P-2	97-463-7	"O" Ring - Retaining Air Harness	3
P-3	201-483-3	Boot - Floorboard (Oval)	1
or	201-483-4	Boot - Floorboard (Oval)	1
or	201-483-5	Boot - Floorboard (Rectangular)	1
	313766X	<b>Shift Knob Assy. (Includes P-4 thru P-11)</b>	1
P-4	201-20-6	Insert - Shift Pattern	1
P-5	201-118-5	Gasket - Shift Knob	1
P-6	500370-4	Nut - Shift Knob Retaining	1
P-7	500357-13	Washer - Shift Knob Retaining	1
P-8	204-W	Washer - Shift Knob Stop	1
P-9	N.S.S	Knob - Shift Air Valve (Serviced as 313766X)	1
P-10	201-205-1	Index Washer	1
P-11	201-438-8	Roll Pin - Shift Knob	1
N.S.	201-420-7	Tube Support	A/R
	See Note Below	<b>Upper Shift Lever S/Assy. (Includes P-11 and P-12A, B, or C )</b>	1
P-12A	N.S.S.	S/Assy. - Shift Lever (Single Crimp Isolator Style)	1
P-12B	N.S.S.	S/Assy. - Shift Lever (Double Crimp Isolator Style) (Includes Lower End)	1
P-12C	See Special Note	S/Assy. - Shift Lever (Double Pin Isolator Style)	1
P-13	545063	Set Screw (Single Crimp Style Isolator Only)	1
	See Special Note	<b>Kit - Shift Lever Isolator (Includes P-14 thru P-17)</b>	
P-14	See Special Note	Isolator	
P-15	See Special Note	Bushing - Isolator	
P-16	See Special Note	Pin - Isolator	
P-17	See Special Note	Ring - Isolator "E" Snap	
<b>SPECIAL NOTE: THIS STYLE OF ISOLATOR IS NO LONGER AVAILABLE. TO REPLACE IT, CALL THE SPICER SUPPORT LINE AT (800)666-8688 WITH PART NUMBERS (25Q-XXXX) FROM UPPER AND LOWER LEVERS.</b>			
	See Note Below	<b>Lower Lever and Tower Assy. (Includes. P-18 thru P-25)</b>	1
P-18	101-483-2	Boot - Shift Tower & Lever	1
N.S.	33Q-15-1	Tie - Cable (Upper)	1
N.S.	33Q-15-2	Tie - Cable (Lower)	1
P-19	97-381-11	Snap Ring	1
P-20	34Q-8	Ring - Outer	2
P-21	34Q-7	Ring - Inner	2
P-22A	See Note Below	Shift Lever - Lower End (Single Crimp Isolator Style Only)	1
N.S.	See Special Note	Shift Lever - Lower End (Double Pin Style)	1
P-23	201-72-3	Spring - Disc	2
N.S.	201-17-2X	S/Assy. - Tower Housing (Includes P-24 & P-25)	1
or	201-17-3X	S/Assy. - Tower Housing (Includes P-24 & P-25)	1
P-24	N.S.S.	Tower - (6.312" Fulcrum) (Serviced as 201-17-2X)	1
or	N.S.S.	Tower - (5.312" Fulcrum) (Serviced as 201-17-3X)	1
P-25	312268	Breather	1
<b>NOTE: PART NUMBERS FOR TOWER AND LEVER ASSEMBLIES CAN BE OBTAINED BY CALLING THE SPICER SUPPORT LINE AT (800)666-8688. CHECK EXISTING LEVER(S) FOR PART NUMBERS (25Q-XXXX).</b>			
		<b>Following Parts are not included in above Assemblies:</b>	
P-26	201-118-2	Gasket - Tower Housing	1
P-27	545028-2	Screw - Tower Housing	6

N.S. - Not Shown      N.S.S. - Not Sold Separately      A/R - As Required

**PRO-SHIFT 10 SPEED MODELS (1400-1650 lb-ft)  
REMOTE CONTROL and RELATED PARTS**



**T210-PSO140-10S**

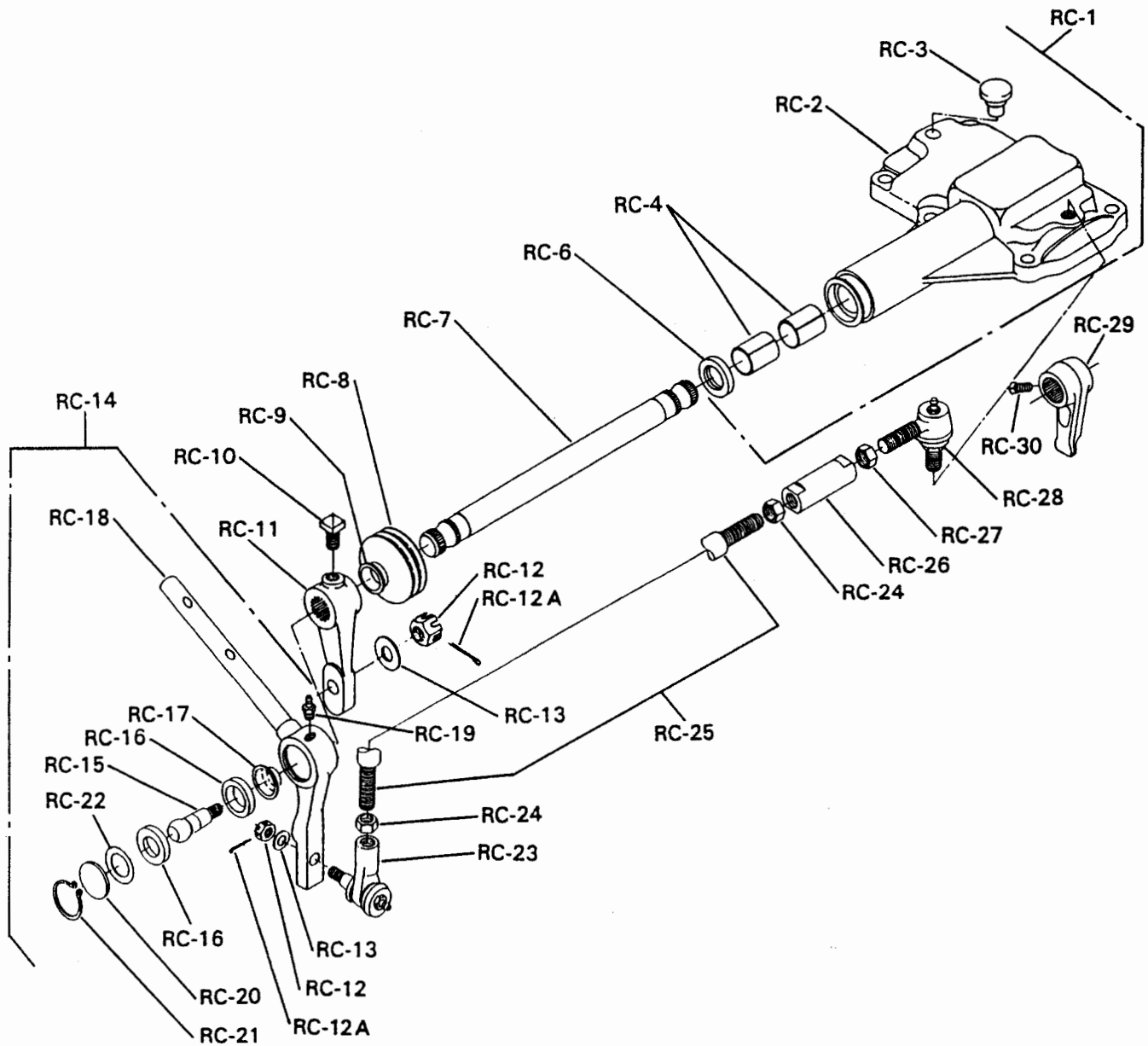



**PRO-SHIFT 10 SPEED MODELS (1400-1650 lb-ft)  
REMOTE CONTROL and RELATED PARTS**

**T210-PSO140-10S**

Ref. No.	Part No.	Description	Qty.
RC-1	201-18-6-3X	<b>Remote Control Assembly</b>	1
	201-18-6X	<b>S/Assy. - Remote Control Housing, Bushings and Ball Joint</b> (Includes RC-2 thru RC-6 and RC-28)	1
RC-2	N.S.S.	Remote Control Housing	1
RC-3	312268	Breather Assembly	1
RC-4	40-24-1	Bushing - Remote Control Housing	2
RC-6	28P-19	Seal - Remote Control Housing	1
RC-7	201-65-5	Rod - Inner Shift Control	1
RC-8	97-483-3	Boot - Shift Rod Rubber	1
RC-9	33Q-15-1	Tie - Cable	2
RC-10	545136	Bolt - Outer Shift Lever	1
RC-11	201-6-3	Lever - Remote Outer Shift Control	1
RC-12	500371-3	Nut - Ball Stud	2
RC-12	500024-5	Cotter Pin	1
RC-13	500362-11	Lock Washer	2
RC-14	201-6-11-1X	<b>S/Assy. - Selector Lever and Arm (Includes RC-15 thru RC-22)</b>	1
RC-15	545117	Ball - Stud Selection Lever	1
RC-16	201-999-3	Bearing - Race Selector Lever	2
RC-17	201-483-2	Boot - Selection Lever	1
RC-18	N.S.S.	Lever - Selection	1
N.S.	313727X	Kit - Grease Parts (Includes RC-19 and RC-20)	1
RC-19	N.S.S.	Nipple - Selection Lever	1
RC-20	N.S.S.	Retainer - Selection Lever	1
RC-21	201-381-4	Snap Ring - Selection Lever	1
RC-22	201-72-10	Spring - Disc Selection Lever	1
RC-23	313673	Ball Joint - Female	1
RC-24	545114	Jam Nut - Turnbuckle	2
RC-25	201-65-6	Tie Rod	1
RC-26	73Q-2	Turn Buckle	1
RC-27	545113	Jam Nut - Turnbuckle (Left Hand)	1
RC-28	313715	Ball Joint - Male (.500-13 UNC thread on end into Housing)	1
RC-29	201-6-2	Finger - Inner Shift	1
RC-30	545137	Screw - Shift Finger	1
		<b>Following Parts are not included in above Assembly:</b>	
N.S.	545028-2	Screw - Control Housing (.438"-14 x 1.500")	6
N.S.	201-118-2	Gasket - Tower Housing	1

N.S. - Not Shown      N.S.S. - Not Sold Separately

# PRO-SHIFT 10 SPEED MODELS (1400-1650 lb-ft) CLUTCH RELEASE CODE TABLE



**T210-PSO140-10S**

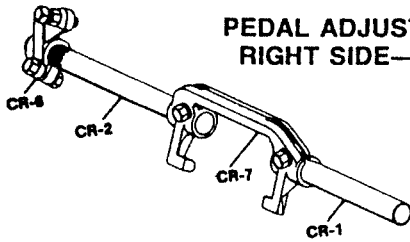

**PEDAL ADJUSTING ARM  
RIGHT SIDE—310473X**

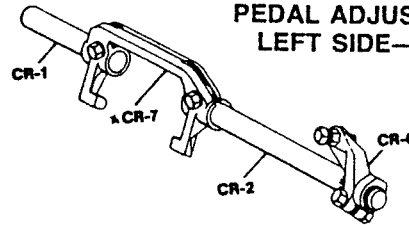

**PEDAL ADJUSTING ARM  
LEFT SIDE—310233X**

**CR-1 SHORT SHAFT**

Part No.	Length
106C-1071	4.062"
106C-1141	5.125"
106C-1142	6.125"
106C-1185	5.750"
106C-1216	4.750"
106C-1278	4.812"
106C-1360	5.312"
106C-1375	6.781"
106C-1498	6.500"
106C-1544	7.000"
330601-1	6.250"

**CR-2 LONG SHAFT (Cont'd)**

Part No.	Type	Length
106C-1083	RS-8	7.969"
106C-1094	RS-8	8.469"
106C-1123	RS-8	12.968"
106C-1169	RS-8	9.125"
106C-1315	RS-8	7.625"
106C-1367	RS-8	10.312"
106C-1375	RS-8	6.781"
106C-1417	RS-8	7.250"
106C-1422	RS-8	7.500"
106C-1490	RS-8	16.000"
106C-1515	RS-5	11.375"
106C-1529	RS-5	8.312"
330610-5	RS-8	9.469"
330610-11	RS-8	10.750"
46-510-9	RS-5	7.125"
330610-10	RS-8	9.500"



**CR-2 LONG SHAFT**

Part No.	Type	Length
106C-438	RS-5	14.000"
106C-588	RS-5	7.000"
106C-617	RS-8	10.469"
106C-839	RS-8	11.469"
106C-939	RS-8	10.000"
106C-953	RS-8	9.750"
106C-959	RS-8	11.968"
106C-960	RS-8	8.719"
106C-1046	RS-8	8.968"
106C-1047	RS-8	9.469"

**CR-6 PEDAL ADJ. ARM**

- 310233X For Left Side Mtg.
  - 310473X For Right Side Mtg.
  - 47-526-1-1X\* Lever Type 7/4"
  - 310873X\* Lever Type 7/4"
- \*Lever type can be used on either right or left side.

**THRU SHAFT (used with Push Type Clutch)**

Part No.	Type	Length
106C-1566	Splined	19.125"
106C-1550	Keyed	16.375"
106C-1558	Keyed	19.000"
106C-1578	Splined	19.500"
49-510-1	Keyed	19.120"
97-510-2	Splined	19.313"

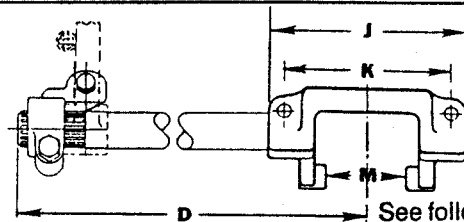

See following page for "D" dimensions.

**CLUTCH RELEASE YOKES**

CR-7	Forging No.	Used With	Type	J	K	M
105C-64	F105C64	Spicer 15 1/2" SP	Pull	8.000"	6.500"	4.895"
105C-68	F105C99	Spicer 14" SP	Pull	7.125"	5.750"	4.132"
105C-117 <sup>1</sup>	F105C118	Spicer & Others	Push	8.375"	7.000"	4.885"
105C-124 ■	F105C125	Spicer AL & AR	Push	3.750"	2.125"	2.885"
105C-132 <sup>2</sup>	F105C118	Spicer & Others	Push	8.375"	7.000"	4.885"
105C-137	F105C138	Spicer 13" and 14" 2P	Pull	8.000"	6.500"	4.895"
85-509-3 <sup>3</sup>	F105C118	Spicer & Others	Push	8.375"	7.000"	4.885"

<sup>1</sup>Machined washer surface on yoke front  
<sup>2</sup>Machined washer surface on yoke rear (for clearance)  
<sup>3</sup>Same as <sup>1</sup> above except contains spring holes in lugs  
 ■ Use 7743X Clutch Release Bearing and (2) 230C-12 Springs.

★ CLUTCH RELEASE YOKE ATTACHING PARTS—  
 Use one KEY 10-30, two SCREWS 330231 and two LOCK WASHERS 500356-12  
 NOTE: When changing from a two plate to single plate clutch or vice versa, a different bearing cap will be required.



## PRO-SHIFT 10 SPEED MODELS (1400-1650 lb-ft) CLUTCH RELEASE CODE TABLE

**T210-PSO140-10S**

Rel.Code See Tab Bill	CR-7 Yoke ★	Shaft		Adjustable Arm	D Dim. (In.)	Rel.Code See Tab Bill	CR-7 Yoke ★	Shaft		Adjustable Arm	D Dim. (In.)
		CR-1 Short	CR-2 Long					CR-1 Short	CR-2 Long		
1	105C-64	106C-1142	106C-1047	310233X	11.969	60	105C-137	106C-1185	106C-617	310233X	12.969
2	105C-64	106C-1185	106C-438	—	16.500	61	105C-137	106C-1185	106C-839	310233X	13.969
3	105C-64	106C-1185	106C-939	310233X	12.500	62	105C-137	106C-1185	106C-939	310233X	12.500
4	105C-64	106C-1185	106C-1046	310233X	11.468	63	105C-137	106C-1185	106C-939	310473X	12.500
5	105C-64	106C-1185	106C-1047	310233X	11.969	64	105C-137	106C-1185	106C-953	310473X	12.250
6	105C-64	106C-1185	106C-1047	47-526-1-1X	11.969	65	105C-137	106C-1185	106C-1046	310233X	11.468
7	105C-64	106C-1544	106C-839	310233X	13.969	66	105C-137	106C-1185	106C-1046	310473X	11.468
8	105C-68	106C-1142	106C-438	—	16.125	67	105C-137	106C-1185	106C-1047	310233X	11.969
9	105C-68	106C-1142	106C-617	—	12.594	68	105C-137	106C-1185	106C-1083	310233X	10.469
10	105C-68	106C-1142	106C-617	310233X	12.594	69	105C-137	106C-1185	106C-1094	—	10.969
11	105C-68	106C-1142	106C-839	310233X	13.594	70	105C-137	106C-1185	106C-1094	310233X	10.969
12	105C-68	106C-1142	106C-939	310233X	12.125	71	105C-137	106C-1185	106C-1123	—	15.468
13	105C-68	106C-1142	106C-1046	310233X	11.093	72	105C-137	106C-1185	106C-1123	310233X	15.468
14	105C-68	106C-1142	106C-1047	310233X	11.594	73	105C-137	106C-1185	106C-1367	—	12.812
15	105C-68	106C-1278	106C-438	—	16.125	74	105C-137	106C-1185	106C-1367	310233X	12.812
15A	105C-68	106C-1278	106C-939	310473X	12.125	75	105C-137	106C-1185	106C-1375	310873X	9.281
15B	105C-68	106C-1278	106C-939	310233X	12.125	76	105C-137	106C-1185	106C-1515	—	13.875
16	105C-117	106C-1071	106C-939	310233X	12.750	77	105C-137	106C-1185	106C-1529	—	10.812
17	105C-117	106C-1071	106C-1094	310233X	11.219	78	105C-137	106C-1185	330610-5	—	11.969
18	105C-117	106C-1142	106C-939	310233X	12.750	78A	105C-137	106C-1185	46-510-9	—	9.625
19	105C-117	106C-1185	106C-438	—	16.750	79	105C-137	106C-1216	106C-617	310233X	12.969
20	105C-117	106C-1185	106C-617	310233X	13.219	80	105C-137	106C-1278	106C-438	—	16.500
21	105C-117	106C-1185	106C-839	47-526-1-1X	14.219	81	105C-137	106C-1278	106C-588	—	9.500
22	105C-117	106C-1185	106C-939	310233X	12.750	82	105C-137	106C-1278	106C-588	310233X	9.500
23	105C-117	106C-1185	106C-953	310873X	12.500	83	105C-137	106C-1278	106C-617	310233X	12.969
24	105C-117	106C-1185	106C-960	310233X	11.469	84	105C-137	106C-1278	106C-939	310233X	12.500
25	105C-117	106C-1185	106C-1046	310233X	11.718	84A	105C-137	106C-1278	106C-939	310473X	12.500
26	105C-117	106C-1185	106C-1047	310233X	12.219	85	105C-137	106C-1278	106C-939	310873X	12.500
27	105C-117	106C-1185	106C-1083	—	10.719	86	105C-137	106C-1278	106C-960	310233X	11.219
28	105C-117	106C-1185	106C-1083	310233X	10.719	87	105C-137	106C-1278	106C-1046	—	11.468
29	105C-117	106C-1185	106C-1083	310473X	10.719	88	105C-137	106C-1278	106C-1046	310233X	11.468
30	105C-117	106C-1185	106C-1094	310233X	11.219	89	105C-137	106C-1278	106C-1047	—	11.969
31	105C-117	106C-1185	106C-1094	310873X	11.219	90	105C-137	106C-1278	106C-1047	310233X	11.969
32	105C-117	106C-1185	106C-1169	310233X	11.875	91	105C-137	106C-1278	106C-1083	310233X	10.469
33	105C-117	106C-1185	106C-1315	—	10.375	91A	105C-137	106C-1278	106C-1083	310473X	10.469
34	105C-117	106C-1185	106C-1315	310233X	10.375	92	105C-137	106C-1278	106C-1094	310233X	10.969
35	105C-117	106C-1185	106C-1315	47-526-1-1X	10.375	92A	105C-137	106C-1278	106C-1315	310233X	10.125
35A	105C-117	106C-1185	106C-1375	310873X	9.531	93	105C-137	106C-1278	106C-1375	310233X	9.281
36	105C-117	106C-1185	106C-1417	310233X	10.000	94	105C-137	106C-1278	106C-1422	310233X	10.000
37	105C-117	106C-1185	106C-1417	310873X	10.000	95	105C-137	106C-1278	106C-1529	—	10.812
38	105C-117	106C-1185	106C-1490	310233X	18.750	96	105C-137	106C-1360	106C-1083	—	10.469
39	105C-117	106C-1278	106C-939	310233X	12.750	96A	105C-137	106C-1360	106C-1417	310233X	9.750
40	105C-117	106C-1278	106C-960	310873X	11.469	97	105C-137	106C-1360	106C-1422	310233X	10.000
41	105C-117	106C-1278	106C-1047	310233X	12.219	98	105C-137	106C-1375	106C-438	310233X	16.500
42	105C-117	106C-1278	106C-1094	310233X	11.219	99	105C-137	106C-1498	106C-438	—	16.500
43	105C-117	106C-1278	106C-1315	310233X	10.375	100	105C-137	106C-1498	106C-617	310233X	12.969
44	105C-117	106C-1278	106C-1367	310233X	13.062	101	105C-137	106C-1498	106C-617	310473X	12.969
45	105C-117	106C-1360	106C-1083	310233X	10.719	102	105C-137	106C-1498	106C-939	310233X	12.500
46	105C-117	106C-1360	106C-1315	310233X	10.375	103	105C-137	106C-1498	106C-939	310473X	12.500
46A	105C-117	106C-1360	330610-10	—	12.250	104	105C-137	106C-1498	106C-953	310233X	12.250
47	105C-117	Thru Shaft	106C-1550	—	—	105	105C-137	106C-1498	106C-959	310233X	14.468
48	105C-117	Thru Shaft	106C-1558	—	—	106	105C-137	106C-1498	106C-1046	310233X	11.468
49	105C-124	106C-1185	106C-438	—	14.313	107	105C-137	106C-1498	106C-1047	—	11.969
50	105C-124	Thru Shaft	106C-1566	310233X	—	108	105C-137	106C-1498	106C-1047	310233X	11.969
51	105C-124	Thru Shaft	106C-1566	310473X	—	109	105C-137	106C-1498	106C-1083	310233X	10.469
52	105C-124	Thru Shaft	106C-1566	310873X	—	110	105C-137	106C-1498	106C-1094	—	10.969
52A	105C-124	Thru Shaft	49-510-1	310233X	—	111	105C-137	106C-1498	330610-11	310233X	13.250
53	105C-132	106C-1185	106C-1047	310233X	9.782	112	105C-137	330601-1	106C-939	310233X	12.500
54	105C-132	106C-1185	106C-1083	310233X	8.282	112A	85-509-3	106C-1278	106C-939	310233X	12.750
55	105C-132	106C-1185	106C-1417	310873X	7.563	113	85-509-3	106C-1360	106C-1417	310233X	10.000
56	105C-132	106C-1185	46-510-9	—	7.438	114	85-509-3	Thru Shaft	106C-1578	310233X	—
57	105C-132	106C-1278	46-510-9	—	7.438	114A	85-509-3	Thru Shaft	106C-1578	310473X	—
58	105C-137	106C-1141	106C-1169	310233X	11.625	115	85-509-3	Thru Shaft	106C-1578	310873X	—
59	105C-137	106C-1185	106C-438	—	16.500	116	312916	Thru Shaft	97-510-2	—	—

■ Use 7743X Clutch Release Bearing and (2) 230C-12 Springs.

**PRO-SHIFT 10 SPEED MODELS (1400-1650 lb-ft)  
SERVICE PARTS OVERHAUL KITS**



**T210-PSO140-10S**

Part No.	Description	Qty.
201-400-1x	<b>Major Overhaul Kit</b>	1
313432-33X	Kit - Minor Overhaul	1
313669X	Kit - Range Piston Housing Repair	1
313429-23X	Kit - Shift Tower Repair Parts	1
201-210-4-1	Key - Countershaft Gear Rear	2
201-210-4-2	Key - Countershaft Gear Middle	2
201-210-4-3	Key - Countershaft Gear Front	2
201-438-6-1X	Kit - Overdrive Shift Fork Mounting Pin and Snap Ring	1
201-438-7-1X	Kit - Overdrive Shift Fork Bracket Pin and Snap Rings	1
201-47-4	Washer - Output Shaft Thrust (Range)	1
201-47-6	Ring - Range Mainshaft Drive Gear Thrust	1
330955	Washer - Countershaft Reverse Idler Thrust (Range)	2
500007-24	Key - Woodruff PTO Gear	2
545065	Nut - Mainshaft	1
313432-33X	<b>Minor Overhaul Kit (Included in Major Overhaul Kit)</b>	1
2367	Manual - Service (PSO-10)	1
2370	Manual - Service (Automate)	1
2783	Bulletin - Mainshaft nut (Loctite Application)	1
312475-45X	Kit - Gasket	1
313667X	Kit - Shim	1
201-381-1	Ring - Snap Input Shaft	1
201-381-3	Ring - Snap Mainshaft Range Drive Gear	1
201-463-26	"O" Ring - Countershaft Front	2
2863	Bulletin - "O" Ring Installation Instructions for Spicer Lite Series	1
201-463-8	Seal - Output Shaft Rear Bearing Cap	1
545080-1	Anaerobic Sealant - Mainshaft Nut (0.5 cc vial)	1
97-463-36-1X	Oil Seal - Drive Gear Bearing Cap (w/ Installation Tool)	1
	<b>Bearings - Range Section</b>	
313628X	S/Assy. - Bearing and Spacer Output Shaft	1
313668X	Kit - Output Shaft Gear Needle Bearing	1
550996	Bearing - Countershaft Front	2
550998	Bearing - Countershaft Rear	2
	<b>Bearings - Main Section</b>	
313645X	S/Assy. - Bearing and Belleville Snap Ring (Input Shaft)	1
550182	Bearing - Countershaft Rear Cone	2
550375	Bearing - Countershaft Rear Cup	2
550375	Bearing - Countershaft Front Cup (After SSN #J930506005)	2
551010	Bearing - Countershaft Front Cup (Before SSN #J930506005)	2
551011	Bearing - Countershaft Front Cone (Before SSN #J930506005)	2
551013	Bearing - Countershaft Front Cone (After SSN #J930506005)	2
550997	Bearing - Reverse Idler Needle	2



**PRO-SHIFT 10 SPEED MODELS (1400-1650 lb-ft)  
SERVICE PARTS OVERHAUL KITS**

<b>Part No.</b>	<b>Description</b>	<b>Qty.</b>
<b>313669X</b>	<b>Kit - Range Piston Housing Repair (Included in Major Overhaul Kit)</b>	<b>1</b>
<b>183-463-6</b>	"O"-Ring - Splitter or Range Piston	1
<b>201-463-1</b>	"O"-Ring - Range Shift Piston	1
<b>201-463-2</b>	"O"-Ring - Range Piston Housing	1
<b>201-463-3</b>	"O"-Ring - Range Piston Rod	1
<b>2726</b>	Bulletin - "O" Ring Lubrication Instruction	1
<b>330895</b>	Lubricant - "O" Ring	1
<b>313429-23X</b>	<b>Kit - Shift Tower Small Parts Repair (Included in Major Overhaul Kit)</b>	<b>1</b>
<b>201-438-2</b>	Pin - Actuating Back-up Light	1
<b>201-438-5</b>	Pin - Air Control Valve	3
<b>201-487-1</b>	Insert - Poppet Spring and Ball	3
<b>201-72-2</b>	Spring - Shift Rail Poppet	3
<b>201-80-1</b>	Ball - Poppet	3
<b>40-438-1</b>	Pin - 1st and Reverse Select Plunger	2
<b>20172-6</b>	Spring - 1st and Reverse Shift Plunger	2
<b>312475-45X</b>	<b>Gasket Kit (Included in Major and Minor Overhaul Kit)</b>	<b>1</b>
<b>201-118-1</b>	Gasket - Williams Air Control Valve	1
<b>201-118-2</b>	Gasket - Tower Housing	1
<b>201-155-3</b>	Gasket - Upper Tower	1
<b>2824</b>	Bulletin - Anaerobic Sealant Application	1
<b>545056-10</b>	Anaerobic Sealant - 50cc Tube	1
<b>313667X</b>	<b>Shim Kit (Included in Major and Minor Overhaul Kit)</b>	<b>1</b>
<b>2825</b>	Bulletin - Countershaft Shim Instructions	1
<b>201-228-1-1</b>	Shim - Countershaft Rear Bearing (.005" thick)	4
<b>201-228-1-2</b>	Shim - Countershaft Rear Bearing (.010" thick)	4
<b>201-228-1-3</b>	Shim - Countershaft Rear Bearing (.015" thick)	4
<b>201-228-1-4</b>	Shim - Countershaft Rear Bearing (.020" thick)	4
<b>201-228-1-5</b>	Shim - Countershaft Rear Bearing (.030" thick)	4
<b>201-228-2-1</b>	Shim - Output Shaft (.005" thick)	1
<b>201-228-2-2</b>	Shim - Output Shaft (.010" thick)	1
<b>201-228-2-3</b>	Shim - Output Shaft (.015" thick)	1
<b>201-228-2-4</b>	Shim - Output Shaft (.020" thick)	1
<b>201-228-2-5</b>	Shim - Output Shaft (.030" thick)	1

**PRO-SHIFT 10 SPEED MODELS (1400-1650 lb-ft)**  
**Oil Cooler and Pump Diagram**



**T210-PSO140-10S**

Ref. No.	Part No.	Description	Qty.
CP-1	313292-1X	<b>Kit - Countershaft Oil Pump</b>	1
CP-1A	313292	Oil Pump	1
CP-2	545005-7	Screw - Oil Pump (.312-18 x .875)	4
CP-3	70-223-25	Gasket - Countershaft Oil Pump Mounting	1
CP-4	201-22-2	Countershaft Rear Bearing Cap Adapter (Right Side)	1
CP-5	313117-5	Hose Assembly. - Outlet to Pump Inlet	1
CP-6	313697X	Filter - Oil Screen	1
CP-7	545002-1	Screw - Countershaft Rear Bearing Cap	4
CP-8	545051	Elbow - Oil Return Hole and Pump Inlet	2
CP-9	545049-2	Nipple - Pump Outlet	1
CP-10	545140	Elbow - Pump Outlet	1
N.S.	2834	Bulletin - Installation	1
N.S.	545056-10	Anaerobic Sealant - 50cc Tube	1

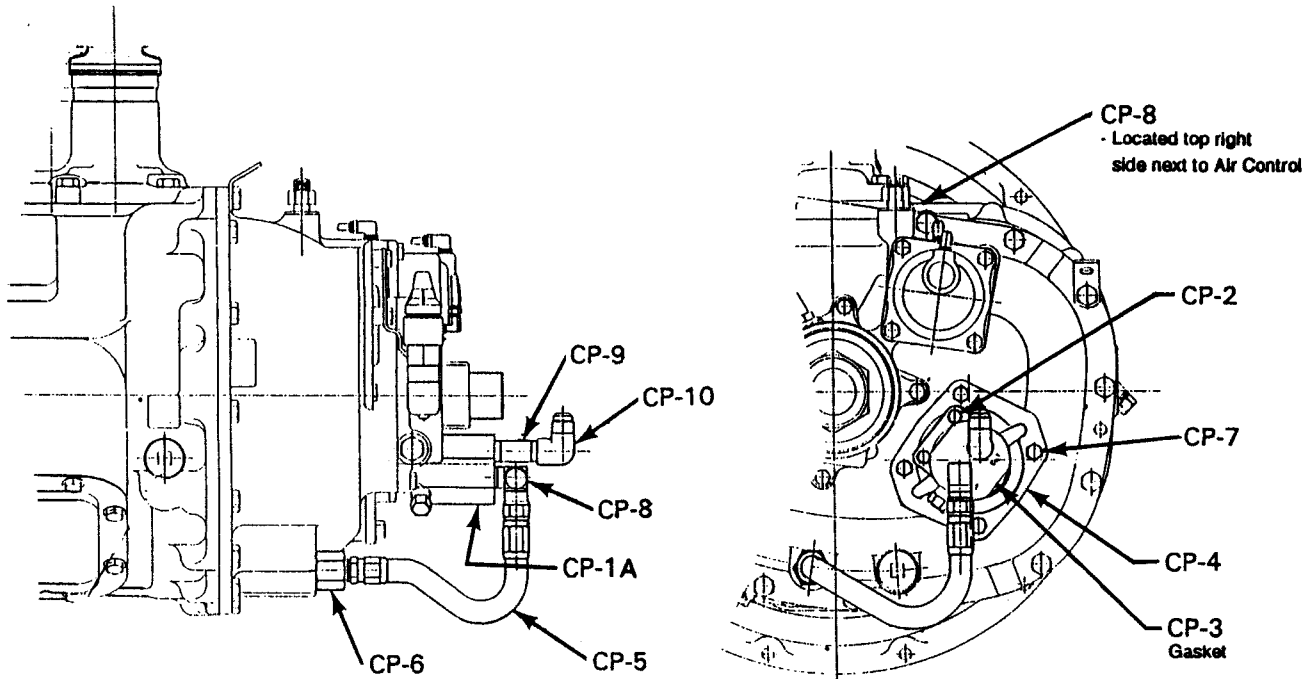

N.S. - Not Shown



## PRO-SHIFT 10 SPEED MODELS (1400-1650 lb-ft) DIRECT AIR CONTROLS DIAGRAM

T210-PSO140-10S

Ref. No.	Part No.	Description	Qty.
AC-1	201-420-2-3	Tubing - Air .250" O.D. (Red)	1
AC-2	201-420-3-3	Tubing - Air .250" O.D. (Green)	1
AC-3	201-420-4-3	Tubing - Air .250" O.D. (Black)	1
N.S.	201-420-9	Tubing - Convoluted Conduit	1

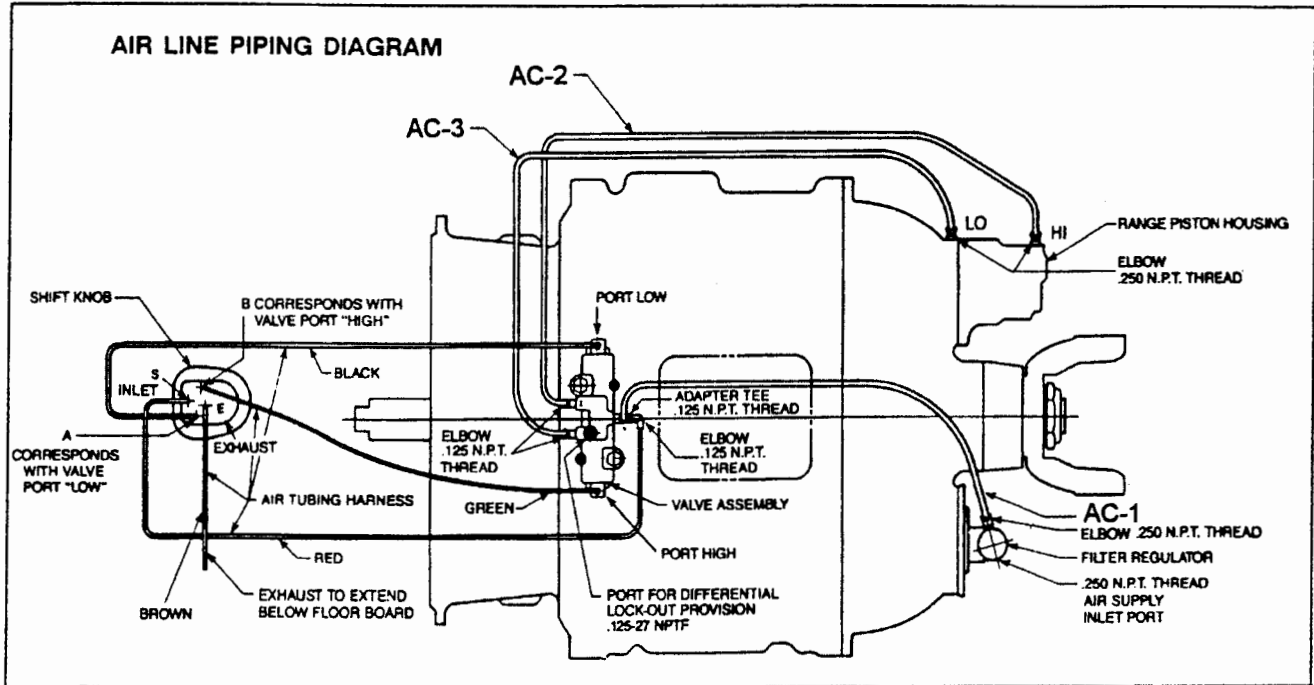

N.S. - Not Shown

**PRO-SHIFT 10 SPEED MODELS (1400-1650 lb-ft)  
TABULATED BILLS OF MATERIAL**



**T210-PSO140-10S**

Tab No.	Used By	For Use With Clutch	Clutch Housing			Main Drive Gear	Drive Gear Bearing Cap	Case Assembly Front
			S A E	Assembly Number	Rel. Code			
<b>Model PS86-10V</b>								
<b>301587</b>								
-1	Navistar	Pull Type	2	201-518-14-5X	-	201-35-7	201-19-2-1X	201-15-13-1X
-2	Navistar	Pull Type	1	201-518-10-5X	-	201-35-7	201-19-2-1X	201-15-13-1X
-3	Freightliner	Pull Type	2	201-518-14-5X	-	201-35-2	201-19-2-1X	201-15-13-1X
<b>Model PSO115-10V</b>								
<b>301588</b>								
-1	Navistar	Pull Type	1	201-518-10-5X	-	201-35-2	201-19-2-1X	201-15-13-1X
-2	Ford	Pull Type	2	201-518-14-5X	-	201-35-7	201-19-2-1X	201-15-9-1X
<b>Model PSO125-10V</b>								
<b>301589</b>								
-1	Navistar	Pull Type	1	201-518-10-5X	-	201-35-2	201-19-2-1X	201-15-13-1X
<b>Model PSO140-10S</b>								
<b>301562</b>								
-1	Navistar	Pull Type	1	201-518-10-5X	-	201-35-2	201-19-2-1X	201-15-13-1X
-2	General	Pull Type	1	201-518-12-5X **	-	201-35-2	201-19-2-1X	201-15-13-1X
-3	Unassigned							
-4	Peterbilt	Pull Type	1	201-518-10-5X	-	201-35-2	201-19-2-1X	201-15-13-1X
-5	Spicer Australia	Pull Type	1	201-518-10-5X	-	201-35-2	201-19-2-1X	201-15-13-1X
-6	Volvo/GM	Pull Type	1	201-518-12-5X **	-	201-35-2	201-19-2-1X	201-15-13-1X
-7	Kenworth	Pull Type	1	201-518-10-5X	-	201-35-2	201-19-2-1X	201-15-13-1X
-8	Freightliner	Pull Type	1	201-518-10-5X	-	201-35-2	201-19-2-1X	201-15-13-1X
-9	Volvo/GM	Pull Type	1	201-518-12-5X **	-	201-35-2	201-19-2-1X	201-15-13-1X
-10	Kenworth	Pull Type	1	201-518-10-5X	-	201-35-2	201-19-2-1X	201-15-13-1X
-11	Kenworth	Pull Type	1	201-518-10-5X	-	201-35-2	201-19-2-1X	201-15-13-1X
-12	Ford	Pull Type	2	201-518-14-5X	-	201-35-2	201-19-2-1X	201-15-9-1X
-13	Ford	Pull Type	2	201-518-14-5X	-	201-35-2	201-19-2-1X	201-15-9-1X
-14	Mack	Pull Type	1	201-518-12-5X **	-	201-35-2	201-19-2-1X	201-15-13-1X
-15	Freightliner	Pull Type	1	201-518-10-5X	-	201-35-2	201-19-2-1X	201-15-13-1X
-16	Unassigned							
-17	Kenworth	Pull Type	1	201-518-10-5X	-	201-35-2	201-19-2-1X	201-15-13-1X
-18	Ford	Pull Type	1	201-518-10-5X	-	201-35-2	201-19-2-1X	201-15-9-1X
-19	Ford	Pull Type	1	201-518-10-5X	-	201-35-2	201-19-2-1X	201-15-9-1X
-20	Mack	Pull Type	1	201-518-12-5X **	-	201-35-2	201-19-2-1X	201-15-13-1X
-21	Motorcoach/Ameri	Pull Type	1	201-518-10-5X	62	201-35-2	201-19-2-1X	201-15-13-1X
-22	Western Star	Pull Type	1	201-518-12-5X **	-	201-35-2	201-19-2-1X	201-15-13-1X
-23	Ford	Pull Type	1	201-518-10-5X	-	201-35-2	201-19-2-1X	201-15-9-1X
-24	Ford	Pull Type	1	201-518-10-5X	-	201-35-2	201-19-2-1X	201-15-9-1X
-25	Marmon	Pull Type	1	201-518-10-5X	-	201-35-2	201-19-2-1X	201-15-13-1X
-26	Mack	Pull Type	1	201-518-12-5X **	-	201-35-2	201-19-2-1X	201-15-13-1X
-27	Eurotruck F.A.P.	Pull Type	1	201-518-10-5X	62	201-35-2	201-19-2-1X	201-15-13-1X

\* - These units have Countershaft Oil Pump. Reference page 30 for Service part numbers

\*\* - These units have Nodal Mount Clutch Housings.



**PRO-SHIFT 10 SPEED MODELS (1400-1650 lb-ft)  
TABULATED BILLS OF MATERIAL**

**T210-PSO140-10S**

Tab No.	Case Assembly Rear	Mainshaft Rear Bearing Cap Assembly	Speedometer Gears		End Yoke or Companion Flange	Lever and Tower Control Assembly	Remote Control Assembly
			Drive or Signal	Driven			
<b>Model PS86-10V</b>							
<b>301587</b>							
-1	201-15-3-1X	201-19-5-2X *	-	-	-	-	-
-2	201-15-3-1X	201-19-5-2X *	-	-	-	-	-
-3	201-15-3-1X	201-19-8-1X	201-452-1	-	6.3-4-651-1	-	-
<b>Model PSO115-10V</b>							
<b>301588</b>							
-1	201-15-3-1X	201-19-5-2X *	-	-	-	-	-
-2	201-15-3-1X	201-19-5-2X *	-	-	6-4-6611-1	-	-
<b>Model PSO125-10V</b>							
<b>301589</b>							
-1	201-15-3-1X	201-19-5-2X *	-	-	-	-	-
<b>Model PSO140-10S</b>							
<b>301562</b>							
-1	201-15-3-1X	201-19-5-2X *	-	-	-	-	-
-2	201-15-3-1X	201-19-5-2X *	-	-	-	-	-
-3	Unassigned						
-4	201-15-3-1X	201-19-8-1X	-	-	-	-	-
-5	201-15-3-1X	201-19-8-1X	201-452-1	-	6.5-4-3451-1	201-17-2-20X	-
-6	201-15-3-1X	201-19-5-2X *	201-452-1	-	6.3-4-651-1	-	-
-7	201-15-3-1X	201-19-5-2X *	201-452-1	-	6-4-6611-1	-	-
-8	201-15-3-1X	201-19-8-1X	201-452-1	-	6.3-4-651-1	-	-
-9	201-15-3-1X	201-19-5-2X *	201-452-1	-	-	-	-
-10	201-15-3-1X	201-19-5-2X *	201-452-1	-	6.3-4-651-1	-	-
-11	201-15-3-1X	201-19-5-2X *	201-452-1	-	6.5-4-3451-1	-	-
-12	201-15-3-1X	201-19-5-2X *	201-452-1	-	6.5-4-3451-1	-	-
-13	201-15-3-1X	201-19-5-2X *	201-452-1	-	6.5-4-3451-1	-	-
-14	201-15-3-1X	201-19-5-2X *	201-452-1	-	6-4-6611	-	-
-15	201-15-3-1X	201-19-8-1X	201-452-1	-	6.3-4-651-1	-	-
-16	Unassigned						
-17	201-15-3-1X	201-19-5-2X *	201-452-1	-	6-4-6611-1	-	-
-18	201-15-3-1X	201-19-5-2X *	201-452-1	-	6.5-4-3451-1	-	-
-19	201-15-3-1X	201-19-5-2X *	201-452-1	-	6.5-4-3451-1	-	-
-20	201-15-3-1X	201-19-5-2X *	201-452-1	-	6.3-4-651-1	-	-
-21	201-15-3-1X	201-19-5-2X *	201-452-1	-	6.5-4-3451-1	-	201-18-6-1X
-22	201-15-3-1X	201-19-5-2X *	201-452-1	-	-	-	-
-23	201-15-3-1X	201-19-5-2X *	201-452-1	-	6.3-4-651-1	-	-
-24	201-15-3-1X	201-19-5-2X *	201-452-1	-	6.5-4-3451-1	-	-
-25	201-15-3-1X	201-19-5-2X *	201-452-1	-	6-4-6611-1	201-17-2-76X	-
-26	201-15-3-1X	201-19-5-2X *	201-452-1	-	6-4-6611-1	-	-
-27	201-15-3-1X	201-19-8-1X	201-452-2	97-453-1	6-1-6011	-	201-18-6-1X

\* - These Mainshaft Rear Bearing Caps are Serviced with Part No. 201-19-8-1X which is a Mech./Elct. Cap.

**PRO-SHIFT 10 SPEED MODELS (1400-1650 lb-ft)  
TABULATED BILLS OF MATERIAL**



**T210-PSO140-10S**

Tab No.	Used By	For Use With Clutch	Clutch Housing			Main Drive Gear	Drive Gear Bearing Cap	Case Assembly Front
			S A E	Assembly Number	Rel. Code			
<b>Model LPSO140-10S</b>								
<b>301573</b>								
-1	Unassigned							
-2	Navistar	Pull Type	1	201-518-8-4X	-	201-35-2	201-19-2-1X	201-15-13-1X
-3	Kenworth	Pull Type	1	201-518-8-4X	-	201-35-2	201-19-2-1X	201-15-13-1X
-4	Unassigned							
-5	Peterbilt	Pull Type	1	201-518-8-4X	-	201-35-2	201-19-2-1X	201-15-13-1X
<b>Model LLPSO140-10S</b>								
<b>301705</b>								
-1	Peterbilt	Pull Type	1	201-518-8-4X	-	201-35-2	201-19-2-1X	201-15-10-1X
-2	Freightliner	Pull Type	1	201-518-20-2X	-	201-35-2	201-19-2-1X	201-15-10-1X
<b>Model PS145-10D</b>								
<b>301607</b>								
-1	General	Pull Type	1	201-518-10-5X	-	201-35-2	201-19-2-1X	201-15-13-1X
-2	Mack	Pull Type	1	201-518-12-5X **	-	201-35-2	201-19-2-1X	201-15-13-1X
-3	Navistar	Pull Type	1	201-518-10-5X	-	201-35-2	201-19-2-1X	201-15-13-1X
<b>Model LPS145-10D</b>								
<b>301611</b>								
-1	General	Pull Type	1	201-518-8-4X	-	201-35-2	201-19-2-1X	201-15-13-1X
-2	Unassigned							
-3	Unassigned							
-4	Unassigned							
-5	Spicer Australia	Pull Type	1	201-518-8-4X	-	201-35-2	201-19-2-1X	201-15-13-1X
<b>Model LLPS145-10D</b>								
<b>301703</b>								
-1	General	Pull Type	1	201-518-8-4X	-	201-35-2	201-19-2-1X	201-15-10-1X
-2	Unassigned							
-3	Unassigned							
-4	Unassigned							
-5	Spicer Australia	Pull Type	1	201-518-8-4X	-	201-35-2	201-19-2-1X	201-15-10-1X
<b>Model PSO145-10V</b>								
<b>301582</b>								
-1	General	Pull Type	1	201-518-10-5X	-	201-35-2	201-19-2-1X	201-15-13-1X
-2	Ford	Pull Type	1	201-518-10-5X	-	201-35-2	201-19-2-1X	201-15-9-1X
-3	Navistar	Pull Type	1	201-518-10-5X	-	201-35-2	201-19-2-1X	201-15-13-1X

\* - These units have Countershaft Oil Pump. Reference page 30 for Service part numbers

\*\* - These units have Nodal Mount Clutch Housings.



**PRO-SHIFT 10 SPEED MODELS (1400-1650 lb-ft)  
TABULATED BILLS OF MATERIAL**

**T210-PSO140-10S**

Tab No.	Case Assembly Rear	Mainshaft Rear Bearing Cap Assembly	Speedometer Gears		End Yoke or Companion Flange	Lever and Tower Control Assembly	Remote Control Assembly
			Drive or Signal	Driven			
<b>Model LPSO140-10S</b>							
<b>301573</b>							
-1	Unassigned						
-2	201-15-3-1X	201-19-5-2X *	-	-	-	-	-
-3	201-15-3-1X	201-19-5-2X *	201-452-1	-	6-4-6611-1	-	-
-4	Unassigned						
-5	201-15-3-1X	201-19-8-1X	-	-	-	-	-
<b>Model LLPSO140-10S</b>							
<b>301705</b>							
-1	201-15-3-1X	201-19-8-1X	-	-	-	-	-
-2	201-15-3-1X	201-19-8-1X	201-452-1	-	6.3-4-651-1	-	-
<b>Model PS145-10D</b>							
<b>301607</b>							
-1	201-15-3-1X	201-19-5-2X *	-	-	-	-	-
-2	201-15-3-1X	201-19-5-2X *	201-452-1	-	6.5-4-3451-1	-	-
-3	201-15-3-1X	201-19-5-2X *	-	-	-	-	-
<b>Model LPS145-10D</b>							
<b>301611</b>							
-1	201-15-3-1X	201-19-5-2X *	-	-	-	-	-
-2	Unassigned						
-3	Unassigned						
-4	Unassigned						
-5	201-15-3-1X	201-19-8-1X	-	-	-	-	-
<b>Model LLPS145-10D</b>							
<b>301703</b>							
-1	201-15-3-1X	201-19-5-2X *	-	-	-	-	-
-2	Unassigned						
-3	Unassigned						
-4	Unassigned						
-5	201-15-3-1X	201-19-8-1X	-	-	-	-	-
<b>Model PSO145-10V</b>							
<b>301582</b>							
-1	201-15-3-1X	201-19-5-2X *	-	-	-	-	-
-2	201-15-3-1X	201-19-5-2X *	201-452-1	-	6.5-4-3451-1	-	-
-3	201-15-3-1X	201-19-5-2X *	-	-	-	-	-

\* - These Mainshaft Rear Bearing Caps are Serviced with Part No. 201-19-8-1X which is a Mech./Elct. Cap.

**PRO-SHIFT 10 SPEED MODELS (1400-1650 lb-ft)  
TABULATED BILLS OF MATERIAL**



**T210-PSO140-10S**

Tab No.	Used By	For Use With Clutch	Clutch Housing			Main Drive Gear	Drive Gear Bearing Cap	Case Assembly Front
			S A E	Assembly Number	Rel. Code			
<b>Model PSO150-10S</b>								
<b>301563</b>								
-1	Navistar	Pull Type	1	201-518-10-5X	-	201-35-2	201-19-2-1X	201-15-13-1X
-2	General	Pull Type	1	201-518-12-5X **	-	201-35-2	201-19-2-1X	201-15-13-1X
-3	Navistar	Pull Type	1	201-518-10-5X	-	201-35-2	201-19-2-1X	201-15-13-1X
-4	Mexico TSP	Pull Type	1	201-518-10-5X	-	201-35-2	201-19-2-1X	201-15-13-1X
-5	Spicer Australia	Pull Type	1	201-518-10-5X	-	201-35-2	201-19-2-1X	201-15-13-1X
-6	Volvo/GM	Pull Type	1	201-518-12-5X **	-	201-35-2	201-19-2-1X	201-15-13-1X
-7	Navistar	Pull Type	1	201-518-10-5X	62	201-35-2	201-19-2-1X	201-15-13-1X
-8	Unassigned							
-9	Freightliner	Pull Type	1	201-518-10-5X	-	201-35-2	201-19-2-1X	201-15-13-1X
-10	Spicer Australia	Pull Type	1	201-518-12-5X **	-	201-35-2	201-19-2-1X	201-15-13-1X
-11	Unassigned							
-12	Peterbilt	Pull Type	1	201-518-10-5X	-	201-35-2	201-19-2-1X	201-15-9-1X
-13	Kenworth	Pull Type	1	201-518-10-5X	-	201-35-2	201-19-2-1X	201-15-13-1X
-14	Ford	Pull Type	1	201-518-10-5X	-	201-35-2	201-19-2-1X	201-15-9-1X
-15	Ford	Pull Type	1	201-518-10-5X	-	201-35-2	201-19-2-1X	201-15-9-1X
-16	Freightliner	Pull Type	1	201-518-10-5X	-	201-35-2	201-19-2-1X	201-15-13-1X
-17	Kenworth	Pull Type	1	201-518-10-5X	62	201-35-2	201-19-2-1X	201-15-13-1X
-18	Marmon	Pull Type	1	201-518-10-5X	-	201-35-2	201-19-2-1X	201-15-13-1X
-19	Mack	Pull Type	1	201-518-12-5X **	-	201-35-2	201-19-2-1X	201-15-13-1X
-20	Navistar	Pull Type	1	201-518-21-2X	-	201-35-2	201-19-2-1X	201-15-13-1X

**Model LPSO150-10S**

**301574**

-1	Navistar	Pull Type	1	201-518-8-4X	-	201-35-2	201-19-2-1X	201-15-13-1X
-2	General	Pull Type	1	201-518-8-4X	-	201-35-2	201-19-2-1X	201-15-13-1X
-3	Unassigned							
-4	Mexico TSP	Pull Type	1	201-518-8-4X	-	201-35-2	201-19-2-1X	201-15-13-1X
-5	Spicer Australia	Pull Type	1	201-518-19-2X**	-	201-35-2	201-19-2-1X	201-15-13-1X
-6	Navistar	Pull Type	1	201-518-20-2X	-	201-35-2	201-19-2-1X	201-15-13-1X

**Model LLPSO150-10S**

**301706**

-1	Navistar	Pull Type	1	201-518-8-4X	-	201-35-2	201-19-2-1X	201-15-10-1X
-2	Peterbilt	Pull Type	1	201-518-8-4X	-	201-35-2	201-19-2-1X	201-15-10-1X

**Model PSO165-10S**

**301564**

-1	Navistar	Pull Type	1	201-518-10-5X	-	201-35-2	201-19-2-1X	201-15-13-1X
-2	Kenworth	Pull Type	1	201-518-10-5X	-	201-35-2	201-19-2-1X	201-15-13-1X
-3	Kenworth	Pull Type	1	201-518-10-5X	-	201-35-2	201-19-2-1X	201-15-13-1X
-4	Kenworth	Pull Type	1	201-518-10-5X	-	201-35-2	201-19-2-1X	201-15-13-1X

\* - These units have Countershaft Oil Pump. Reference page 30 for Service part numbers

\*\* - These units have Nodal Mount Clutch Housings.



**PRO-SHIFT 10 SPEED MODELS (1400-1650 lb-ft)  
TABULATED BILLS OF MATERIAL**

**T210-PSO140-10S**

Tab No.	Case Assembly Rear	Mainshaft Rear Bearing Cap Assembly	Speedometer Gears		End Yoke or Companion Flange	Lever and Tower Control Assembly	Remote Control Assembly
			Drive or Signal	Driven			

**Model PSO150-10S**

**301563**

-1	201-15-3-1X	201-19-5-2X *	-	-	-	-	-
-2	201-15-3-1X	201-19-5-2X *	-	-	-	-	-
-3	201-15-3-1X	201-19-5-2X *	-	-	-	-	-
-4	201-15-3-1X	201-19-8-1X	201-452-1	-	6.5-4-3451-1	201-17-2-30X	-
-5	201-15-3-1X	201-19-8-1X	-	-	-	-	-
-6	201-15-3-1X	201-19-5-2X *	201-452-1	-	-	-	-
-7	201-15-3-1X	201-19-8-1X	201-452-2	97-453-1	6-4-6611	201-17-2-1X	-
-8	Unassigned						
-9	201-15-3-1X	201-19-8-1X	201-452-1	-	6.3-4-651-1	-	-
-10	201-15-3-1X	201-19-8-1X	-	-	-	-	-
-11	Unassigned						
-12	201-15-3-1X	201-19-8-1X	-	-	-	-	-
-13	201-15-3-1X	201-19-5-2X *	201-452-1	-	6.3-4-651-1	-	-
-14	201-15-3-1X	201-19-8-1X	201-452-1	-	6.5-4-3451-1	-	-
-15	201-15-3-1X	201-19-8-1X	201-452-1	-	6.5-4-3451-1	-	-
-16	201-15-3-1X	201-19-8-1X	201-452-1	-	6.3-4-651	-	-
-17	201-15-3-1X	201-19-5-2X *	201-452-1	-	6-4-6611-1	-	-
-18	201-15-3-1X	201-19-5-2X *	201-452-1	-	6.5-4-3451	201-17-2-76X	-
-19	201-15-3-1X	201-19-5-2X *	201-452-1	-	6.3-4-651-1	-	-
-20	201-15-3-1X	201-19-5-2X *	-	-	-	-	-

**Model LPSO150-10S**

**301574**

-1	201-15-3-1X	201-19-5-2X *	-	-	-	-	-
-2	201-15-3-1X	201-19-5-2X *	-	-	-	-	-
-3	Unassigned						
-4	201-15-3-1X	201-19-8-1X	-	-	-	-	-
-5	201-15-3-1X	201-19-5-2X *	201-452-1	-	6.3-4-651-1	-	-
-6	201-15-3-1X	201-19-5-2X *	-	-	-	-	-

**Model LLPSO150-10S**

**301706**

-1	201-15-3-1X	201-19-5-2X *	-	-	-	-	-
-2	201-15-3-1X	201-19-8-1X	-	-	-	-	-

**Model PSO165-10S**

**301564**

-1	201-15-3-1X	201-19-5-2X *	-	-	-	-	-
-2	201-15-3-1X	201-19-5-2X *	201-452-1	-	6-4-6611-1	-	-
-3	201-15-3-1X	201-19-5-2X *	201-452-1	-	6.3-4-651-1	-	-
-4	201-15-3-1X	201-19-5-2X *	201-452-1	-	6.5-4-3451-1	-	-

\* - These Mainshaft Rear Bearing Caps are Serviced with Part No. 201-19-8-1X which is a Mech/Elct. Cap.

**PRO-SHIFT 10 SPEED MODELS (1400-1650 lb-ft)  
TABULATED BILLS OF MATERIAL**



**T210-PSO140-10S**

Tab No.	Used By	For Use With Clutch	Clutch Housing			Main Drive Gear	Drive Gear Bearing Cap	Case Assembly Front
			S A E	Assembly Number	Rel. Code			

**Model PSO165-10S (Cont'd.)**

**301564**

-5	Spicer Australia	Pull Type	1	201-518-10-5X	-	201-35-2	201-19-2-1X	201-15-13-1X
-6	Spicer Australia	Pull Type	1	201-518-12-5X **	-	201-35-2	201-19-2-1X	201-15-13-1X
-7	Peterbilt	Pull Type	1	201-518-10-5X	-	201-35-2	201-19-2-1X	201-15-13-1X
-8	Marmon	Pull Type	1	201-518-10-5X	-	201-35-2	201-19-2-1X	201-15-13-1X
-9	Ford	Pull Type	2	201-518-14-5X	-	201-35-2	201-19-2-1X	201-15-9-1X
-10	Mack	Pull Type	1	201-518-12-5X **	-	201-35-2	201-19-2-1X	201-15-13-1X
-11	Navistar	Pull Type	1	201-518-21-2X	-	201-35-2	201-19-2-1X	201-15-13-1X

**Model PSO140-10S**

**301506**

*-1	Navistar	Pull Type	1	201-518-10-2X	-	201-35-2	201-19-2-1X	201-15-2-1X
*-2	General	Pull Type	1	201-518-12-2X **	-	201-35-2	201-19-2-1X	201-15-2-1X
-3	Navistar	Pull Type	1	201-518-10-2X	-	201-35-2	201-19-2-1X	201-15-2-1X
-4	Peterbilt	Pull Type	1	201-518-10-2X	-	201-35-2	201-19-2-1X	201-15-2-1X
*-5	Spicer Australia	Pull Type	1	201-518-10-2X	-	201-35-2	201-19-2-1X	201-15-2-1X
-6	Volvo/GM	Pull Type	1	201-518-12-2X **	-	201-35-2	201-19-2-1X	201-15-2-1X
-7	Kenworth	Pull Type	1	201-518-10-2X	-	201-35-2	201-19-2-1X	201-15-2-1X
-8	Freightliner	Pull Type	1	201-518-10-2X	-	201-35-2	201-19-2-1X	201-15-2-1X
-9	Volvo/GM	Pull Type	1	201-518-12-2X **	-	201-35-2	201-19-2-1X	201-15-2-1X
-10	Kenworth	Pull Type	1	201-518-10-2X	-	201-35-2	201-19-2-1X	201-15-2-1X
-11	Kenworth	Pull Type	1	201-518-10-2X	-	201-35-2	201-19-2-1X	201-15-2-1X
-12	Ford	Pull Type	2	201-518-14-2X	-	201-35-2	201-19-2-1X	201-15-2-1X
-13	Ford	Pull Type	2	201-518-14-2X	-	201-35-2	201-19-2-1X	201-15-2-1X
-14	Mack	Pull Type	1	201-518-12-2X **	-	201-35-2	201-19-2-1X	201-15-2-1X
-15	Freightliner	Pull Type	1	201-518-10-2X	-	201-35-2	201-19-2-1X	201-15-2-1X
*-16	Kenworth	Pull Type	1	201-518-10-2X	-	201-35-2	201-19-2-1X	201-15-2-1X
*-17	Kenworth	Pull Type	1	201-518-10-2X	-	201-35-2	201-19-2-1X	201-15-2-1X
-18	Ford	Pull Type	1	201-518-10-2X	-	201-35-2	201-19-2-1X	201-15-2-1X
-19	Ford	Pull Type	1	201-518-10-2X	-	201-35-2	201-19-2-1X	201-15-2-1X
-20	Mack	Pull Type	1	201-518-12-2X **	-	201-35-2	201-19-2-1X	201-15-2-1X
*-21	Motorcoach/Ameri	Pull Type	1	201-518-10-2X	62	201-35-2	201-19-2-1X	201-15-2-1X
*-22	Western Star	Pull Type	1	201-518-12-2X **	-	201-35-2	201-19-2-1X	201-15-2-1X
-23	Ford	Pull Type	1	201-518-10-2X	-	201-35-2	201-19-2-1X	201-15-2-1X

**Model LPSO140-10S**

**301545**

-1	Navistar	Pull Type	1	201-518-8-2X	-	201-35-2	201-19-2-1X	201-15-2-1X
*-2	Navistar	Pull Type	1	201-518-8-2X	-	201-35-2	201-19-2-1X	201-15-2-1X
-3	Kenworth	Pull Type	1	201-518-8-2X	-	201-35-2	201-19-2-1X	201-15-2-1X
*-4	Kenworth	Pull Type	1	201-518-8-2X	-	201-35-2	201-19-2-1X	201-15-2-1X

\* - These units have Countershaft Oil Pump. Reference page 30 for Service part numbers

\*\* - These units have Nodal Mount Clutch Housings.



**PRO-SHIFT 10 SPEED MODELS (1400-1650 lb-ft)  
TABULATED BILLS OF MATERIAL**

**T210-PSO140-10S**

Tab No.	Case Assembly Rear	Mainshaft Rear Bearing Cap Assembly	Speedometer Gears		End Yoke or Companion Flange	Lever and Tower Control Assembly	Remote Control Assembly
			Drive or Signal	Driven			

**Model PSO165-10S (Cont'd.)**

**301564**

-5	201-15-3-1X	201-19-8-1X	-	-	-	-	-
-6	201-15-3-1X	201-19-8-1X	-	-	-	-	-
-7	201-15-3-1X	201-19-5-2X *	-	-	-	-	-
-8	201-15-3-1X	201-19-5-2X *	201-452-1	-	6.5-4-3451	-	-
-9	201-15-3-1X	201-19-5-2X *	201-452-1	-	6.5-4-3451-1	-	-
-10	201-15-3-1X	201-19-5-2X *	-	-	6.3-4-651-1	-	-
-11	201-15-3-1X	201-19-5-2X *	-	-	-	-	-

**Model PSO140-10S**

**301506**

-1	201-15-3-1X	201-19-5-2X *	-	-	-	-	-
-2	201-15-3-1X	201-19-5-2X *	-	-	-	-	-
-3	201-15-3-1X	201-19-5-2X *	-	-	-	-	-
-4	201-15-3-1X	201-19-8-1X	-	-	-	-	-
-5	201-15-3-1X	201-19-8-1X	201-452-1	-	6.5-4-3451-1	201-17-2-7X	-
-6	201-15-3-1X	201-19-5-2X *	201-452-1	-	6.3-4-651-1	-	-
-7	201-15-3-1X	201-19-5-2X *	201-452-1	-	6-4-6611-1	-	-
-8	201-15-3-1X	201-19-8-1X	201-452-1	-	6.3-4-651-1	-	-
-9	201-15-3-1X	201-19-5-2X *	201-452-1	-	-	-	-
-10	201-15-3-1X	201-19-5-2X *	201-452-1	-	6.3-4-651-1	-	-
-11	201-15-3-1X	201-19-5-2X *	201-452-1	-	6.5-4-3451-1	-	-
-12	201-15-3-1X	201-19-5-2X *	201-452-1	-	6.5-4-3451-1	-	-
-13	201-15-3-1X	201-19-5-2X *	201-452-1	-	6.5-4-3451-1	-	-
-14	201-15-3-1X	201-19-5-2X *	201-452-1	-	6-4-6611	-	-
-15	201-15-3-1X	201-19-8-1X	201-452-1	-	6.3-4-651-1	-	-
-16	201-15-3-1X	201-19-5-2X *	201-452-1	-	6.3-4-651-1	-	-
-17	201-15-3-1X	201-19-5-2X *	201-452-1	-	6-4-6611-1	-	-
-18	201-15-3-1X	201-19-5-2X *	201-452-1	-	6.5-4-3451-1	-	-
-19	201-15-3-1X	201-19-5-2X *	201-452-1	-	6.5-4-3451-1	-	-
-20	201-15-3-1X	201-19-5-2X *	201-452-1	-	6.3-4-651-1	-	-
-21	201-15-3-1X	201-19-5-2X *	201-452-1	-	6.5-4-3451-1	-	201-18-6-1X
-22	201-15-3-1X	201-19-5-2X *	201-452-1	-	-	-	-
-23	201-15-3-1X	201-19-5-2X *	201-452-1	-	6.3-4-651-1	-	-

**Model LPSO140-10S**

**301545**

-1	201-15-3-1X	201-19-5-2X *	-	-	-	-	-
-2	201-15-3-1X	201-19-5-2X *	-	-	-	-	-
-3	201-15-3-1X	201-19-5-2X *	201-452-1	-	6-4-6611-1	-	-
-4	201-15-3-1X	201-19-5-2X *	201-452-1	-	6-4-6611-1	-	-

\* - These Mainshaft Rear Bearing Caps are Serviced with Part No. 201-19-8-1X which is a Mech/Elct. Cap.

**PRO-SHIFT 10 SPEED MODELS (1400-1650 lb-ft)  
TABULATED BILLS OF MATERIAL**



**T210-PSO140-10S**

Tab No.	Used By	For Use With Clutch	Clutch Housing			Main Drive Gear	Drive Gear Bearing Cap	Case Assembly Front
			S A E	Assembly Number	Rel. Code			

**Model PSO150-10S**

**301503**

*-1	Navistar	Pull Type	1	201-518-10-2X	-	201-35-2	201-19-2-1X	201-15-2-1X
*-2	General	Pull Type	1	201-518-12-2X **	-	201-35-2	201-19-2-1X	201-15-2-1X
*-3	Navistar	Pull Type	1	201-518-10-2X	-	201-35-2	201-19-2-1X	201-15-2-1X
*-4	Mexico TSP	Pull Type	1	201-518-10-2X	-	201-35-2	201-19-2-1X	201-15-2-1X
*-5	Spicer Australia	Pull Type	1	201-518-10-2X	-	201-35-2	201-19-2-1X	201-15-2-1X
-6	Volvo/GM	Pull Type	1	201-518-12-2X **	-	201-35-2	201-19-2-1X	201-15-2-1X
*-7	Navistar	Pull Type	1	201-518-10-2X	62	201-35-2	201-19-2-1X	201-15-2-1X
-8	Navistar	Pull Type	1	201-518-10-2X	-	201-35-2	201-19-2-1X	201-15-2-1X
*-9	Freightliner	Pull Type	1	201-518-10-2X	-	201-35-2	201-19-2-1X	201-15-2-1X
*-10	Spicer Australia	Pull Type	1	201-518-12-2X **	-	201-35-2	201-19-2-1X	201-15-2-1X
*-11	Volvo/GM	Pull Type	1	201-518-12-2X **	-	201-35-2	201-19-2-1X	201-15-2-1X
-12	Peterbilt	Pull Type	1	201-518-10-2X	-	201-35-2	201-19-2-1X	201-15-2-1X
*-13	Kenworth	Pull Type	1	201-518-10-2X	-	201-35-2	201-19-2-1X	201-15-2-1X
*-14	Ford	Pull Type	1	201-518-10-2X	-	201-35-2	201-19-2-1X	201-15-9-1X
-15	Ford	Pull Type	1	201-518-10-2X	-	201-35-2	201-19-2-1X	201-15-9-1X

**Model LPSO150-10S**

**301546**

*-1	Navistar	Pull Type	1	201-518-8-2X	-	201-35-2	201-19-2-1X	201-15-2-1X
-2	Navistar	Pull Type	1	201-518-8-2X	-	201-35-2	201-19-2-1X	201-15-2-1X
*-3	Navistar	Pull Type	1	201-518-8-2X	-	201-35-2	201-19-2-1X	201-15-2-1X

**Model PSO165-10S**

**301523**

*-1	Navistar	Pull Type	1	201-518-10-2X	-	201-35-2	201-19-2-1X	201-15-2-1X
*-2	Kenworth	Pull Type	1	201-518-10-2X	-	201-35-2	201-19-2-1X	201-15-2-1X
*-3	Kenworth	Pull Type	1	201-518-10-2X	-	201-35-2	201-19-2-1X	201-15-2-1X
*-4	Kenworth	Pull Type	1	201-518-10-2X	-	201-35-2	201-19-2-1X	201-15-2-1X
*-5	Spicer Australia	Pull Type	1	201-518-10-2X	-	201-35-2	201-19-2-1X	201-15-2-1X
*-6	Spicer Australia	Pull Type	1	201-518-12-2X **	-	201-35-2	201-19-2-1X	201-15-2-1X

**Model PSO160-10S**

**301517**

*-1	Navistar	Pull Type	1	201-518-10-2X	-	201-35-2	201-19-2-1X	201-15-2-1X
*-2	Kenworth	Pull Type	1	201-518-10-2X	-	201-35-2	201-19-2-1X	201-15-2-1X
*-3	Kenworth	Pull Type	1	201-518-10-2X	-	201-35-2	201-19-2-1X	201-15-2-1X
*-4	Kenworth	Pull Type	1	201-518-10-2X	-	201-35-2	201-19-2-1X	201-15-2-1X
*-5	Spicer Australia	Pull Type	1	201-518-10-2X	-	201-35-2	201-19-2-1X	201-15-2-1X
*-6	Spicer Australia	Pull Type	1	201-518-12-2X **	-	201-35-2	201-19-2-1X	201-15-2-1X

\* - These units have Countershaft Oil Pump. Reference page 30 for Service part numbers

\*\* - These units have Nodal Mount Clutch Housings.



**PRO-SHIFT 10 SPEED MODELS (1400-1650 lb-ft)  
TABULATED BILLS OF MATERIAL**

**T210-PSO140-10S**

Tab No.	Case Assembly Rear	Mainshaft Rear Bearing Cap Assembly	Speedometer Gears		End Yoke or Companion Flange	Lever and Tower Control Assembly	Remote Control Assembly
			Drive or Signal	Driven			

**Model PSO150-10S**

**301503**

-1	201-15-3-1X	201-19-5-2X *	-	-	-	-	-
-2	201-15-3-1X	201-19-5-2X *	-	-	-	-	-
-3	201-15-3-1X	201-19-5-2X *	-	-	-	-	-
-4	201-15-3-1X	201-19-8-1X	201-452-1	-	6.5-4-3451	201-17-2-3X	-
-5	201-15-3-1X	201-19-8-1X	-	-	-	-	-
-6	201-15-3-1X	201-19-5-2X *	201-452-1	-	-	-	-
-7	201-15-3-1X	201-19-8-1X	201-452-2	97-453-1	6-4-6611	201-17-2-1X	-
-8	201-15-3-1X	201-19-8-1X	-	-	-	-	-
-9	201-15-3-1X	201-19-8-1X	201-452-1	-	6.3-4-651-1	-	-
-10	201-15-3-1X	201-19-5-2X *	-	-	-	-	-
-11	201-15-3-1X	201-19-5-2X *	201-452-1	-	-	-	-
-12	201-15-3-1X	201-19-5-2X *	-	-	-	-	-
-13	201-15-3-1X	201-19-5-2X *	201-452-1	-	6.3-4-651-1	-	-
-14	201-15-3-1X	201-19-5-2X *	201-452-1	-	6.5-4-3451-1	-	-
-15	201-15-3-1X	201-19-5-2X *	201-452-1	-	6.5-4-3451-1	-	-

**Model LPSO150-10S**

**301546**

-1	201-15-3-1X	201-19-5-2X *	-	-	-	-	-
-2	201-15-3-1X	201-19-5-2X *	-	-	-	-	-
-3	201-15-3-1X	201-19-5-2X *	-	-	-	-	-

**Model PSO165-10S**

**301523**

-1	201-15-3-1X	201-19-5-2X *	-	-	-	-	-
-2	201-15-3-1X	201-19-5-2X *	201-452-1	-	6-4-6611-1	-	-
-3	201-15-3-1X	201-19-5-2X *	201-452-1	-	6.3-4-651-1	-	-
-4	201-15-3-1X	201-19-5-2X *	201-452-1	-	6.5-4-3451-1	-	-
-5	201-15-3-1X	201-19-5-2X *	-	-	-	-	-
-6	201-15-3-1X	201-19-5-2X *	-	-	-	-	-

**Model PSO160-10S**

**301517**

-1	201-15-3-1X	201-19-5-2X *	-	-	-	-	-
-2	201-15-3-1X	201-19-5-2X *	201-452-1	-	6-4-6611-1	-	-
-3	201-15-3-1X	201-19-5-2X *	201-452-1	-	6.3-4-651-1	-	-
-4	201-15-3-1X	201-19-5-2X *	201-452-1	-	6.5-4-3451-1	-	-
-5	201-15-3-1X	201-19-5-2X *	-	-	-	-	-
-6	201-15-3-1X	201-19-5-2X *	-	-	-	-	-

\* - These Mainshaft Rear Bearing Caps are Serviced with Part No. 201-19-8-1X which is a Mech./Elct. Cap.

**PRO-SHIFT 10 SPEED MODELS (1400-1650 lb-ft)  
SUPERSESSION LIST**



**T210-PSO140-10S**

PS86-10V	PS86-10V	LPSO140-10S	LPSO140-10S	PSO150-10S	PSO150-10S
None	301587-1	301545-1	301573-2	301503-1	301563-1
None	301587-2	301545-2	301573-2	301503-2	301563-2
None	301587-3	301545-3	301573-3	301503-3	301563-3
		301545-4	301573-3	301503-4	301563-4
		None	301573-5	301503-5	301563-5
<b>PSO115-10V</b>	<b>PSO115-10V</b>			301503-6	301563-6
None	301588-1	<b>LLPSO140-10S</b>	<b>LLPSO140-10S</b>	301503-7	301563-7
None	301588-2			301503-8	301563-3
		None	301705-1	301503-9	301563-9
		None	301705-2	301503-10	301563-10
<b>PSO125-10V</b>	<b>PSO125-10V</b>			301503-11	301563-6
None	301589-1			301503-12	301563-12
		<b>PS145-10D</b>	<b>PS145-10D</b>	301503-13	301563-13
				301503-14	301563-14
				301503-15	301563-15
		None	301607-1	None	301563-16
<b>PSO140-10S</b>	<b>PSO140-10S</b>	None	301607-2	None	301563-17
		None	301607-3	None	301563-18
301506-1	301562-1			None	301563-19
301506-2	301562-2			None	301563-20
301506-3	301562-1	<b>LPS145-10D</b>	<b>LPS145-10D</b>		
301506-4	301562-4				
301506-5	301562-5	None	301611-1	<b>LPSO150-10S</b>	<b>LPSO150-10S</b>
301506-6	301562-6	None	301611-2		
301506-7	301562-7	None	301611-3	301546-1	301574-1
301506-8	301562-8	None	301611-4	301546-2	301574-2
301506-9	301562-9	None	301611-5	301546-3	301574-2
301506-10	301562-10			None	301574-4
301506-11	301562-11			None	301574-5
301506-12	301562-12	<b>LLPS145-10D</b>	<b>LLPS145-10D</b>	None	301574-6
301506-13	301562-13				
301506-14	301562-14	None	301703-1		
301506-15	301562-15	None	301703-2	<b>LLPSO150-10S</b>	<b>LLPSO150-10S</b>
301506-16	301562-10	None	301703-3		
301506-17	301562-17	None	301703-4	None	301706-1
301506-18	301562-18	None	301703-5	None	301706-2
301506-19	301562-19				
301506-20	301562-20				
301506-21	301562-21	<b>PSO145-10V</b>	<b>PSO145-10V</b>		
301506-22	301562-22				
301506-23	301562-23	None	301582-1		
None	301562-24	None	301582-2		
None	301562-25	None	301582-3		
None	301562-26				
None	301562-27				



# PRO-SHIFT 10 SPEED MODELS (1400-1650 lb-ft) SUPERSESION LIST

T210-PSO140-10S

PSO160-10S	PSO165-10S	PSO165-10S
301517-1	301523-1	301564-1
301517-2	301523-2	301564-2
301517-3	301523-3	301564-3
301517-4	301523-4	301564-4
301517-5	301523-5	301564-5
301517-6	301523-6	301564-6
None	None	301564-7
None	None	301564-8
None	None	301564-9
None	None	301564-10
None	None	301564-11

